

KEITHLEY

Model 2440 5A SourceMeter®
Service Manual

A GREATER MEASURE OF CONFIDENCE

WARRANTY

Keithley Instruments, Inc. warrants this product to be free from defects in material and workmanship for a period of 1 year from date of shipment.

Keithley Instruments, Inc. warrants the following items for 90 days from the date of shipment: probes, cables, rechargeable batteries, diskettes, and documentation.

During the warranty period, we will, at our option, either repair or replace any product that proves to be defective.

To exercise this warranty, write or call your local Keithley representative, or contact Keithley headquarters in Cleveland, Ohio. You will be given prompt assistance and return instructions. Send the product, transportation prepaid, to the indicated service facility. Repairs will be made and the product returned, transportation prepaid. Repaired or replaced products are warranted for the balance of the original warranty period, or at least 90 days.

LIMITATION OF WARRANTY

This warranty does not apply to defects resulting from product modification without Keithley's express written consent, or misuse of any product or part. This warranty also does not apply to fuses, software, non-rechargeable batteries, damage from battery leakage, or problems arising from normal wear or failure to follow instructions.

THIS WARRANTY IS IN LIEU OF ALL OTHER WARRANTIES, EXPRESSED OR IMPLIED, INCLUDING ANY IMPLIED WARRANTY OF MERCHANTABILITY OR FITNESS FOR A PARTICULAR USE. THE REMEDIES PROVIDED HEREIN ARE BUYER'S SOLE AND EXCLUSIVE REMEDIES.

NEITHER KEITHLEY INSTRUMENTS, INC. NOR ANY OF ITS EMPLOYEES SHALL BE LIABLE FOR ANY DIRECT, INDIRECT, SPECIAL, INCIDENTAL OR CONSEQUENTIAL DAMAGES ARISING OUT OF THE USE OF ITS INSTRUMENTS AND SOFTWARE EVEN IF KEITHLEY INSTRUMENTS, INC., HAS BEEN ADVISED IN ADVANCE OF THE POSSIBILITY OF SUCH DAMAGES. SUCH EXCLUDED DAMAGES SHALL INCLUDE, BUT ARE NOT LIMITED TO: COSTS OF REMOVAL AND INSTALLATION, LOSSES SUSTAINED AS THE RESULT OF INJURY TO ANY PERSON, OR DAMAGE TO PROPERTY.



Keithley Instruments, Inc. • 28775 Aurora Road • Cleveland, OH 44139 • 440-248-0400 • Fax: 440-248-6168 • <http://www.keithley.com>

BELGIUM:

Keithley Instruments B.V.

Bergensesteenweg 709 • B-1600 Sint-Pieters-Leeuw • 02/363 00 40 • Fax: 02/363 00 64

CHINA:

Keithley Instruments China

Yuan Chen Xin Building, Room 705 • 12 Yumin Road, Dewai, Madian • Beijing 100029 • 8610-62022886 • Fax: 8610-62022892

FRANCE:

Keithley Instruments Sarl

3, allée des Garays • 91127 Palaiseau Cedex • 01-64 53 20 20 • Fax: 01-60 11 77 26

GERMANY:

Keithley Instruments GmbH

Landsberger Strasse 65 • 82110 Germering • 089/84 93 07-40 • Fax: 089/84 93 07-34

GREAT BRITAIN:

Keithley Instruments Ltd

Unit 2 Commerce Park, Brunel Road • Theale • Reading • Berkshire RG7 4AB • 0118 929 7500 • Fax: 0118 929 7519

INDIA:

Keithley Instruments GmbH

Flat 2B, WILOCRISSA • 14, Rest House Crescent • Bangalore 560 001 • 91-80-509-1320/21 • Fax: 91-80-509-1322

ITALY:

Keithley Instruments s.r.l.

Viale S. Gimignano, 38 • 20146 Milano • 02-48 39 16 01 • Fax: 02-48 30 22 74

NETHERLANDS:

Keithley Instruments B.V.

Postbus 559 • 4200 AN Gorinchem • 0183-635333 • Fax: 0183-630821

SWITZERLAND:

Keithley Instruments SA

Kriesbachstrasse 4 • 8600 Dübendorf • 01-821 94 44 • Fax: 01-820 30 81

TAIWAN:

Keithley Instruments Taiwan

1 Fl. 85 Po Ai Street • Hsinchu, Taiwan, R.O.C. • 886-3572-9077 • Fax: 886-3572-903

Model 2440 5A SourceMeter® Service Manual

©2001, Keithley Instruments, Inc.
All rights reserved.
Cleveland, Ohio, U.S.A.
First Printing, April 2001
Document Number: 2440-902-01 Rev. A

Manual Print History

The print history shown below lists the printing dates of all Revisions and Addenda created for this manual. The Revision Level letter increases alphabetically as the manual undergoes subsequent updates. Addenda, which are released between Revisions, contain important change information that the user should incorporate immediately into the manual. Addenda are numbered sequentially. When a new Revision is created, all Addenda associated with the previous Revision of the manual are incorporated into the new Revision of the manual. Each new Revision includes a revised copy of this print history page.

Revision A (Document Number 2440-902-01) April 2001

Safety Precautions

The following safety precautions should be observed before using this product and any associated instrumentation. Although some instruments and accessories would normally be used with non-hazardous voltages, there are situations where hazardous conditions may be present.

This product is intended for use by qualified personnel who recognize shock hazards and are familiar with the safety precautions required to avoid possible injury. Read the operating information carefully before using the product.

The types of product users are:

Responsible body is the individual or group responsible for the use and maintenance of equipment, for ensuring that the equipment is operated within its specifications and operating limits, and for ensuring that operators are adequately trained.

Operators use the product for its intended function. They must be trained in electrical safety procedures and proper use of the instrument. They must be protected from electric shock and contact with hazardous live circuits.

Maintenance personnel perform routine procedures on the product to keep it operating, for example, setting the line voltage or replacing consumable materials. Maintenance procedures are described in the manual. The procedures explicitly state if the operator may perform them. Otherwise, they should be performed only by service personnel.

Service personnel are trained to work on live circuits, and perform safe installations and repairs of products. Only properly trained service personnel may perform installation and service procedures.

Keithley products are designed for use with electrical signals that are rated Installation Category I and Installation Category II, as described in the International Electrotechnical Commission (IEC) Standard IEC 60664. Most measurement, control, and data I/O signals are Installation Category I and must not be directly connected to mains voltage or to voltage sources with high transient over-voltages. Installation Category II connections require protection for high transient over-voltages often associated with local AC mains connections. The user should assume all measurement, control, and data I/O connections are for connection to Category I sources unless otherwise marked or described in the Manual.

Exercise extreme caution when a shock hazard is present. Lethal voltage may be present on cable connector jacks or test fixtures. The American National Standards Institute (ANSI) states that a shock hazard exists when voltage levels greater than 30V RMS, 42.4V peak, or 60VDC are present. **A good safety practice is to expect that hazardous voltage is present in any unknown circuit before measuring.**

Users of this product must be protected from electric shock at all times. The responsible body must ensure that users are prevented access and/or insulated from every connection point. In some cases, connections must be exposed to potential human contact. Product users in these circumstances must be trained to protect themselves from the risk of electric shock. If the circuit is capable of operating at or above 1000 volts, **no conductive part of the circuit may be exposed.**

Do not connect switching cards directly to unlimited power circuits. They are intended to be used with impedance limited sources. NEVER connect switching cards directly to AC mains. When connecting sources to switching cards, install protective devices to limit fault current and voltage to the card.

Before operating an instrument, make sure the line cord is connected to a properly grounded power receptacle. Inspect the connecting cables, test leads, and jumpers for possible wear, cracks, or breaks before each use.

When installing equipment where access to the main power cord is restricted, such as rack mounting, a separate main input power disconnect device must be provided, in close proximity to the equipment and within easy reach of the operator.

For maximum safety, do not touch the product, test cables, or any other instruments while power is applied to the circuit under test. ALWAYS remove power from the entire test system and discharge any capacitors before: connecting or disconnecting cables or jumpers, installing or removing switching cards, or making internal changes, such as installing or removing jumpers.

Do not touch any object that could provide a current path to the common side of the circuit under test or power line (earth) ground. Always make measurements with dry hands while standing on a dry, insulated surface capable of withstanding the voltage being measured.

The instrument and accessories must be used in accordance with its specifications and operating instructions or the safety of the equipment may be impaired.

Do not exceed the maximum signal levels of the instruments and accessories, as defined in the specifications and operating information, and as shown on the instrument or test fixture panels, or switching card.

When fuses are used in a product, replace with same type and rating for continued protection against fire hazard.

Chassis connections must only be used as shield connections for measuring circuits, NOT as safety earth ground connections.

If you are using a test fixture, keep the lid closed while power is applied to the device under test. Safe operation requires the use of a lid interlock.

If a  screw is present, connect it to safety earth ground using the wire recommended in the user documentation.

The  symbol on an instrument indicates that the user should refer to the operating instructions located in the manual.

The  symbol on an instrument shows that it can source or measure 1000 volts or more, including the combined effect of normal and common mode voltages. Use standard safety precautions to avoid personal contact with these voltages.

The **WARNING** heading in a manual explains dangers that might result in personal injury or death. Always read the associated information very carefully before performing the indicated procedure.

The **CAUTION** heading in a manual explains hazards that could damage the instrument. Such damage may invalidate the warranty.

Instrumentation and accessories shall not be connected to humans.

Before performing any maintenance, disconnect the line cord and all test cables.

To maintain protection from electric shock and fire, replacement components in mains circuits, including the power transformer, test leads, and input jacks, must be purchased from Keithley Instruments. Standard fuses, with applicable national safety approvals, may be used if the rating and type are the same. Other components that are not safety related may be purchased from other suppliers as long as they are equivalent to the original component. (Note that selected parts should be purchased only through Keithley Instruments to maintain accuracy and functionality of the product.) If you are unsure about the applicability of a replacement component, call a Keithley Instruments office for information.

To clean an instrument, use a damp cloth or mild, water based cleaner. Clean the exterior of the instrument only. Do not apply cleaner directly to the instrument or allow liquids to enter or spill on the instrument. Products that consist of a circuit board with no case or chassis (e.g., data acquisition board for installation into a computer) should never require cleaning if handled according to instructions. If the board becomes contaminated and operation is affected, the board should be returned to the factory for proper cleaning/servicing.

Table of Contents

1	Performance Verification	
	Introduction	1-2
	Verification test requirements	1-2
	Environmental conditions	1-2
	Warm-up period	1-3
	Line power	1-3
	Recommended test equipment	1-3
	1 Ω resistor characterization	1-4
	Verification limits	1-5
	Example limits calculation	1-5
	Resistance limits calculation	1-5
	Restoring factory defaults	1-6
	Performing the verification test procedures	1-6
	Test summary	1-6
	Test considerations	1-7
	Setting the source range and output value	1-7
	Setting the measurement range	1-8
	Compliance considerations	1-8
	Compliance limits	1-8
	Types of compliance	1-8
	Maximum compliance values	1-9
	Determining compliance limit	1-9
	Taking the SourceMeter out of compliance	1-10
	Output voltage accuracy	1-10
	Voltage measurement accuracy	1-12
	Output current accuracy	1-13
	10mA to 1A range accuracy	1-13
	5A range accuracy	1-14
	Current measurement accuracy	1-16
	10mA to 1A range accuracy	1-16
	5A range accuracy	1-17
	Resistance measurement accuracy	1-18

2

Calibration

Introduction	2-2
Environmental conditions	2-2
Temperature and relative humidity	2-2
Warm-up period	2-2
Line power	2-2
Calibration considerations	2-3
Calibration cycle	2-3
Recommended calibration equipment	2-4
1 Ω resistor characterization	2-4
Unlocking calibration	2-5
Unlocking calibration from the front panel	2-5
Unlocking calibration by remote	2-6
Changing the password	2-7
Changing the password from the front panel	2-7
Changing the password by remote	2-7
Resetting the calibration password	2-8
Viewing calibration dates and calibration count	2-8
Calibration errors	2-8
Front panel error reporting	2-8
Remote error reporting	2-9
Front panel calibration	2-9
Step 1: Prepare the Model 2440 for calibration	2-9
Step 2: Voltage calibration	2-10
Step 3: Current calibration	2-13
Step 4: Enter calibration dates and save calibration ..	2-17
Step 5: Lock out calibration	2-17
Remote calibration	2-18
Remote calibration commands	2-18
Recommended calibration parameters	2-19
Remote calibration procedure	2-20
Step 1: Prepare the Model 2440 for calibration	2-20
Step 2: Voltage calibration	2-21
Step 3: Current calibration	2-23
Step 4: Program calibration dates	2-25
Step 5: Save calibration constants	2-25
Step 6: Lock out calibration	2-25
Single-range calibration	2-25

3

Routine Maintenance

Introduction	3-2
Line fuse replacement	3-2

4	Troubleshooting	
	Introduction	4-2
	Repair considerations	4-2
	Power-on self-test	4-2
	Front panel tests	4-3
	KEYS test	4-3
	DISPLAY PATTERNS test	4-3
	CHAR SET test	4-4
	Principles of operation	4-4
	Overall block diagram	4-4
	Analog circuits	4-4
	Power supply	4-7
	Output stage	4-8
	A/D converter	4-9
	Active guard	4-9
	Digital circuitry	4-10
	Display board circuit theory	4-11
	Troubleshooting	4-12
	Display board checks	4-12
	Power supply checks	4-12
	Digital circuitry checks	4-13
	Analog circuitry checks	4-14
	Battery replacement	4-14
	Battery replacement precautions	4-15
	Battery replacement procedure	4-15
	No comm link error	4-16
5	Disassembly	
	Introduction	5-2
	Handling and cleaning	5-2
	Handling PC boards	5-2
	Solder repairs	5-2
	Static sensitive devices	5-3
	Assembly drawings	5-3
	Case cover removal	5-4
	Analog board removal	5-5
	Digital board removal	5-6
	Front panel disassembly	5-6
	Removing power components	5-7
	Power module removal	5-7
	Instrument reassembly	5-7

6	Replaceable Parts	
	Introduction	6-2
	Parts lists	6-2
	Ordering information	6-2
	Factory service	6-2
	Component layouts	6-3

A	Specifications	
----------	-----------------------	--

B	Command Reference	
----------	--------------------------	--

	Introduction	B-2
	Command summary	B-2
	Miscellaneous commands	B-3
	CODE	B-3
	COUNT?	B-3
	LOCK	B-4
	SAVE	B-4
	DATE	B-5
	NDUE	B-5
	SENSE	B-6
	SOURCE	B-7
	DATA?	B-9
	Detecting calibration errors	B-9
	Reading the error queue	B-9
	Error summary	B-9
	Status byte EAV (Error Available) bit	B-10
	Generating an SRQ on error	B-10
	Detecting calibration step completion	B-11
	Using the *OPC? query	B-11
	Using the *OPC command	B-11
	Generating an SRQ on calibration complete	B-12

C	Calibration Programs	
----------	-----------------------------	--

	Introduction	C-2
	Computer hardware requirements	C-2
	Software requirements	C-2
	Calibration equipment	C-2
	General program instructions	C-3
	Program C-1 Model 2440 calibration program	C-4
	Requesting calibration constants	C-7
	Program C-2 Requesting calibration constants	C-7

List of Illustrations

1	Performance Verification	
Figure 1-1	Connections for voltage verification tests	1-10
Figure 1-2	Connections for 10 μ A to 1A range current verification tests	1-13
Figure 1-3	Connections for 5A range current verification tests	1-14
Figure 1-4	Connections for resistance accuracy verification	1-18
2	Calibration	
Figure 2-1	Voltage calibration test connections	2-10
Figure 2-2	10 μ A to 1A range current calibration test connections	2-13
Figure 2-3	5A range current calibration test connections	2-15
3	Routine Maintenance	
Figure 3-1	Rear panel	3-2
4	Troubleshooting	
Figure 4-1	Overall block diagram	4-5
Figure 4-2	Analog circuitry block diagram	4-6
Figure 4-3	Power supply block diagram	4-7
Figure 4-4	Output stage simplified schematic	4-8
Figure 4-5	Digital circuitry block diagram	4-10

List of Tables

1	Performance Verification	
Table 1-1	Recommended verification equipment	1-4
Table 1-2	Maximum compliance values	1-9
Table 1-3	Output voltage accuracy limits	1-11
Table 1-4	Voltage measurement accuracy limits	1-12
Table 1-5	Output current accuracy limits	1-15
Table 1-6	Current measurement accuracy limits	1-17
Table 1-7	Ohms measurement accuracy limits	1-19

2	Calibration	
Table 2-1	Recommended calibration equipment	2-4
Table 2-2	Calibration unlocked states	2-6
Table 2-3	Front panel voltage calibration	2-12
Table 2-4	Front panel current calibration	2-16
Table 2-5	Remote calibration command summary	2-18
Table 2-6	Recommended :CALibration:PROTeCted:SENse parameter ranges	2-19
Table 2-7	Recommended :CALibration:PROTeCted:SOURce parameter ranges	2-20
Table 2-8	Voltage calibration initialization commands	2-22
Table 2-9	Voltage range calibration commands	2-22
Table 2-10	Current calibration initialization commands	2-24
Table 2-11	Current range calibration commands	2-24

3	Routine Maintenance	
Table 3-1	Power line fuse	3-3

4	Troubleshooting	
Table 4-1	Display board checks	4-12
Table 4-2	Power supply checks	4-12
Table 4-3	Digital circuitry checks	4-13
Table 4-4	Analog circuitry checks	4-14

6

Replaceable Parts

Table 6-1	Analog board parts list	6-3
Table 6-2	Digital board parts list	6-12
Table 6-3	Display board parts list	6-17
Table 6-4	Miscellaneous parts list	6-18

B

Command Reference

Table B-1	Remote calibration command summary	B-2
Table B-2	Recommended :CALibration:PROTeCted:SENSe parameter ranges	B-7
Table B-3	Recommended :CALibration:PROTeCted:SOURce parameter ranges	B-8
Table B-4	Calibration errors	B-10

1

Performance Verification

Introduction

Use the procedures in this section to verify that Model 2440 accuracy is within the limits stated in the instrument's one-year accuracy specifications. You can perform these verification procedures:

- When you first receive the instrument to make sure that it was not damaged during shipment.
- To verify that the unit meets factory specifications.
- To determine if calibration is required.
- Following calibration to make sure it was performed properly.

WARNING The information in this section is intended for qualified service personnel only. Do not attempt these procedures unless you are qualified to do so. Some of these procedures may expose you to hazardous voltages, which could cause personal injury or death if contacted. Use standard safety precautions when working with hazardous voltages.

NOTE *If the instrument is still under warranty and its performance is outside specified limits, contact your Keithley representative or the factory to determine the correct course of action.*

Verification test requirements

Be sure that you perform the verification tests:

- Under the proper environmental conditions.
- After the specified warm-up period.
- Using the correct line voltage.
- Using the proper test equipment.
- Using the specified output signals and reading limits.

Environmental conditions

Conduct your performance verification procedures in a test environment with:

- An ambient temperature of 18-28°C (65-82°F).
- A relative humidity of less than 70% unless otherwise noted.

Warm-up period

Allow the Model 2440 to warm up for at least one hour before conducting the verification procedures.

If the instrument has been subjected to temperature extremes (those outside the ranges stated above), allow additional time for the instrument's internal temperature to stabilize. Typically, allow one extra hour to stabilize a unit that is 10°C (18°F) outside the specified temperature range.

Also, allow the test equipment to warm up for the minimum time specified by the manufacturer.

Line power

The Model 2440 requires a line voltage of 88 to 264V and a line frequency of 50 to 60Hz. Verification tests must be performed within this range.

Recommended test equipment

[Table 1-1](#) summarizes recommended verification equipment. You can use alternate equipment as long as that equipment has specifications at least as good as those listed in [Table 1-1](#). Keep in mind, however, that test equipment uncertainty will add to the uncertainty of each measurement. Generally, test equipment uncertainty should be at least four times better than corresponding Model 2440 specifications. [Table 1-1](#) lists the specifications of the recommended test equipment, including maximum allowable uncertainty for alternate test equipment, which is shown in parentheses.

Table 1-1

Recommended verification equipment

Description	Manufacturer/Model	Specifications
Digital Multimeter	Hewlett Packard HP3458A	DC Voltage* 1V: ±5.6ppm 10V: ±4.3ppm 100V: ±6.3ppm DC Current* 10μA: ±25ppm 100μA: ±23ppm 1mA: ±20ppm 10mA: ±20ppm 100mA: ±35ppm 1A: ±110ppm
Resistance Calibrator	Fluke 5450A	Resistance** 1.9Ω: ±65ppm (±460ppm) 19Ω: ±23ppm (±280ppm) 190Ω: ±10.5ppm (±230ppm) 1.9kΩ: ±8ppm (±200ppm) 19kΩ: ±7.5ppm (±195ppm) 190kΩ: ±8.5ppm (±200ppm) 1.9MΩ: ±11.5ppm (±180ppm) 19MΩ: ±30ppm (±635ppm)
Precision Resistor***	Isotec RUG-Z-1R00-0.1	1Ω, ±0.1%, 100W

* 90-day, full-range accuracy specifications of ranges required for various measurement points.

** 90-day, ±5°C specifications of nominal resistance values shown. Use actual values for tests. Maximum uncertainty of alternate test equipment shown in parentheses.

*** Required for verification of 5A current range. Characterize resistor to ±300ppm or better using recommended DMM before verifying 5A current measurement range.

1Ω resistor characterization

The recommended 1Ω resistor should be characterized to ±300ppm or better before verifying the 5A current measurement range. (You need not characterize the resistor if you are checking only the 5A current source range.) Use the 4-wire ohms function of the DMM recommended in [Table 1-1](#) to measure the resistance value, and then use that measured value to calculate the current during the 5A current measurement range test procedure.

Verification limits

The verification limits stated in this section have been calculated using only the Model 2440 one-year accuracy specifications, and they do not include test equipment uncertainty. If a particular measurement falls outside the allowable range, recalculate new limits based on Model 2440 specifications and corresponding test equipment specifications.

Example limits calculation

As an example of how verification limits are calculated, assume you are testing the 10V DC output range using a 10V output value. Using the Model 2440 10V range one-year accuracy specification of $\pm(0.02\%$ of output + 1.2mV offset), the calculated output limits are:

$$\text{Output limits} = 10\text{V} \pm [(10\text{V} \times 0.02\%) + 1.2\text{mV}]$$

$$\text{Output limits} = 10\text{V} \pm (0.002 + 0.0012)$$

$$\text{Output limits} = 10\text{V} \pm 3.2\text{mV}$$

$$\text{Output limits} = 9.9968\text{V to } 10.0032\text{V}$$

Resistance limits calculation

When verifying the resistance measurement accuracy, it will probably be necessary to recalculate resistance limits based on the actual calibrator resistance values. You can calculate resistance reading limits in the same manner described above, but be sure to use the actual calibrator resistance values and the Model 2440 normal accuracy specifications for your calculations.

As an example, assume you are testing the 20k Ω range, and that the actual value of the nominal 19k Ω calibrator resistor is 19.01k Ω . Using the Model 2440 20k Ω range one-year normal accuracy specifications of $\pm(0.066\%$ of reading + 3 Ω), the recalculated reading limits are:

$$\text{Reading limits} = 19.01\text{k}\Omega \pm [(19.01\text{k}\Omega \times 0.066\%) + 3\Omega]$$

$$\text{Reading limits} = 19.01\text{k}\Omega \pm 14.4\Omega$$

$$\text{Reading limits} = 18.9956\text{k}\Omega \text{ to } 19.0244\text{k}\Omega$$

Restoring factory defaults

Before performing the verification procedures, restore the instrument to its factory front panel (bench) defaults as follows:

1. Press the MENU key. The instrument will display the following prompt:
MAIN MENU
SAVESETUP COMMUNICATION CAL ►
2. Select SAVESETUP, and then press ENTER. The unit then displays:
SAVESETUP MENU
GLOBAL SOURCE-MEMORY
3. Select GLOBAL, and then press ENTER. The unit then displays:
GLOBAL SETUP MENU
SAVE RESTORE POWERON RESET
4. Select RESET, and then press ENTER. The unit displays:
RESET ORIGINAL DFLTS
BENCH GPIB
5. Select BENCH, and then press ENTER. The unit then displays:
RESETTING INSTRUMENT
ENTER to confirm; EXIT to abort
6. Press ENTER to restore bench defaults, and note the unit displays the following:
RESET COMPLETE
BENCH defaults are now restored ►
◀ Press ENTER to continue
7. Press ENTER then EXIT as necessary to return to normal display.

Performing the verification test procedures

Test summary

- DC voltage output accuracy
- DC voltage measurement accuracy
- DC current output accuracy
- DC current measurement accuracy
- Resistance measurement accuracy

If the Model 2440 is not within specifications and not under warranty, see the calibration procedures in [Section 2](#) for information on calibrating the unit.

Test considerations

When performing the verification procedures:

- Be sure to restore factory front panel defaults as previously outlined.
- Make sure that the test equipment is properly warmed up and connected to the Model 2440 INPUT/OUTPUT jacks. Also be sure that the front panel jacks are selected with the TERMINALS key.
- Make sure the Model 2440 is set to the correct source range (see below).
- Be sure that the Model 2440 output is turned on before making measurements.
- Be sure the test equipment is set up for the proper function and range.
- Allow the Model 2440 output signal to settle before making a measurement.
- Do not connect test equipment to the Model 2440 through a scanner, multiplexer, or other switching equipment.

WARNING The maximum common-mode voltage (voltage between LO and chassis ground) is 40V peak. Exceeding this value may cause a breakdown in insulation, creating a shock hazard.

CAUTION The maximum voltage between INPUT/OUTPUT HI and LO or 4-WIRE SENSE HI and LO is 42V peak. The maximum voltage between INPUT/OUTPUT HI and 4-WIRE SENSE HI or between INPUT/OUTPUT LO and 4-WIRE SENSE LO is 5V. Exceeding these voltage values may result in instrument damage.

Setting the source range and output value

Before testing each verification point, you must properly set the source range and output value as outlined below.

1. Press either the SOURCE V or SOURCE I key to select the appropriate source function.
2. Press the EDIT key as required to select the source display field. Note that the cursor will flash in the source field while its value is being edited.
3. With the cursor in the source display field flashing, set the source range to the lowest possible range for the value to be sourced using the up or down RANGE key. For example, you should use the 10V source range to output a 10V source value. With a 10V source value and the 10V range selected, the source field display will appear as follows:

Vsrc:+10.0000V

4. With the source field cursor flashing, set the source output to the required value using either:
 - The SOURCE adjustment and left and right arrow keys.
 - The numeric keys.
5. Note that the source output value will be updated immediately; you need not press ENTER when setting the source value.

Setting the measurement range

When simultaneously sourcing and measuring either voltage or current, the measure range is coupled to the source range, and you cannot independently control the measure range. Thus, it is not necessary for you to set the measure range when testing voltage or current measurement accuracy.

Compliance considerations

Compliance limits

When sourcing voltage, you can set the SourceMeter to limit current from 10nA to 5.25A. Conversely, when sourcing current, you can set the SourceMeter to limit voltage from 0.2mV to 42V. The SourceMeter output will not exceed the programmed compliance limit.

Types of compliance

There are two types of compliance that can occur: “real” and “range.” Depending on which value is lower, the output will clamp at either the displayed compliance setting (“real”) or at the maximum measurement range reading (“range”).

The “real” compliance condition can occur when the compliance setting is less than the highest possible reading of the measurement range. When in compliance, the source output clamps at the displayed compliance value. For example, if the compliance voltage is set to 1V and the measurement range is 2V, the output voltage will clamp (limit) at 1V.

“Range” compliance can occur when the compliance setting is higher than the possible reading of the selected measurement range. When in compliance, the source output clamps at the maximum measurement range reading (not the compliance value). For example, if the compliance voltage is set to 1V and the measurement range is 200mV, the output voltage will clamp (limit) at 200mV.

Maximum compliance values

The maximum compliance values for the measurement ranges are summarized in [Table 1-2](#).

Table 1-2

Maximum compliance values

Measurement range	Maximum compliance value
200mV	210mV
2V	2.1V
10V	10.5V
40V	42V
10μA	10.5μA
100μA	105μA
1mA	1.05mA
10mA	10.5mA
100mA	105mA
1A	1.05A
5A	5.25A

When the SourceMeter goes into compliance, the “Cmpl” label or the units label (i.e., “mA”) for the compliance display will flash.

Determining compliance limit

The relationships to determine which compliance is in effect are summarized as follows. They assume that the measurement function is the same as the compliance function.

- Compliance Setting < Measurement Range = Real Compliance
- Measurement Range < Compliance Setting = Range Compliance

You can determine the compliance that is in effect by comparing the displayed compliance setting to the present measurement range. If the compliance setting is lower than the maximum possible reading on the present measurement range, the compliance setting is the compliance limit. If the compliance setting is higher than the measurement range, the maximum reading on that measurement range is the compliance limit.

Taking the SourceMeter out of compliance

Verification measurements should not be made when the SourceMeter is in compliance. For purposes of the verification tests, the SourceMeter can be taken out of compliance by going into the edit mode and increasing the compliance limit.

NOTE Do not take the unit out of compliance by decreasing the source value or changing the range. Always use the recommended range and source settings when performing the verification tests.

Output voltage accuracy

Follow the steps below to verify that Model 2440 output voltage accuracy is within specified limits. This test involves setting the output voltage to each full-range value and measuring the voltages with a precision digital multimeter.

1. With the power off, connect the digital multimeter to the Model 2440 INPUT/OUTPUT jacks, as shown in Figure 1-1.

Figure 1-1
Connections for voltage verification tests

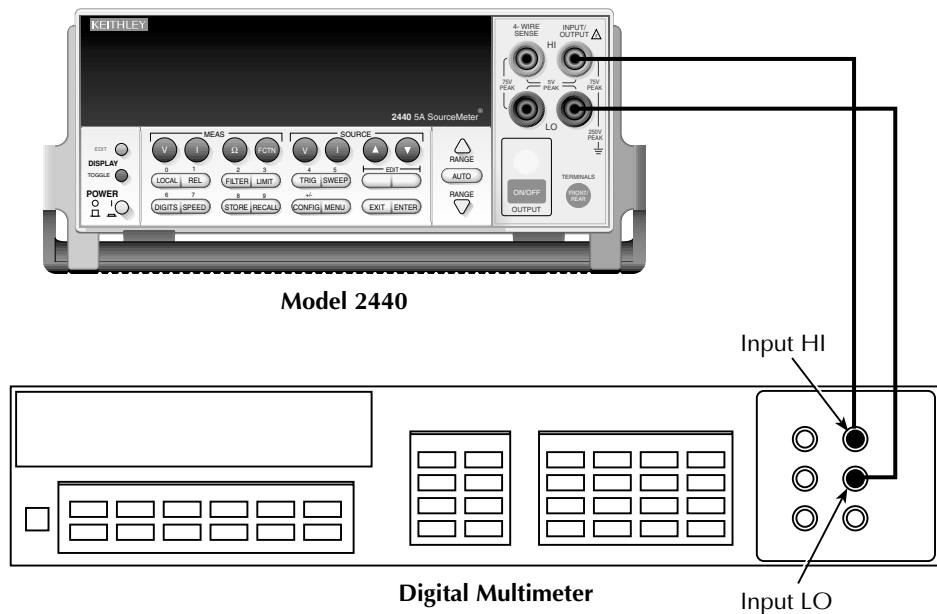

2. Select the multimeter DC volts measuring function.
3. Set the voltage source protection to NONE. To do so, press CONFIG then SOURCE V to access the CONFIGURE V-SOURCE menu. Select PROTECTION, and set the voltage source protection limit to NONE.
4. Press the Model 2440 SOURCE V key to source voltage, and make sure the source output is turned on.
5. Verify output voltage accuracy for each of the voltages listed in Table 1-3. For each test point:
 - Select the correct source range.
 - Set the Model 2440 output voltage to the indicated value.
 - Verify that the multimeter reading is within the limits given in the table.
6. Repeat the procedure for negative output voltages with the same magnitudes as those listed in Table 1-3.
7. Repeat the entire procedure using the rear panel INPUT/OUTPUT jacks. Be sure to select the rear panel jacks with the front panel TERMINALS key.

Table 1-3

Output voltage accuracy limits

Model 2440 source range	Model 2440 output voltage setting	Output voltage limits (1 year, 18°C-28°C)
200mV	200.000mV	199.360 to 200.640mV
2V	2.00000V	1.99900 to 2.00100V
10V	10.0000V	9.9968 to 10.0032V
40V	40.0000V	39.9872 to 40.0128V

Voltage measurement accuracy

Follow the steps below to verify that Model 2440 voltage measurement accuracy is within specified limits. The test involves setting the source voltage to full-range values, as measured by a precision digital multimeter, and then verifying that the Model 2440 voltage readings are within required limits.

1. With the power off, connect the digital multimeter to the Model 2440 INPUT/OUTPUT jacks, as shown in [Figure 1-1](#).
2. Select the multimeter DC volts function.
3. Set the voltage source protection to NONE. To do so, press CONFIG then SOURCE V to access the CONFIGURE V-SOURCE menu. Select PROTECTION, and set the voltage source protection limit to NONE.
4. Set the Model 2440 to both source and measure voltage by pressing the SOURCE V and MEAS V keys, and make sure the source output is turned on.
5. Verify output voltage accuracy for each of the voltages listed in [Table 1-4](#). For each test point:
 - Select the correct source range.
 - Set the Model 2440 output voltage to the indicated value as measured by the digital multimeter.
 - Verify that the Model 2440 voltage reading is within the limits given in the table.

NOTE *It may not be possible to set the voltage source to the specified value. Use the closest possible setting, and modify reading limits accordingly.*

6. Repeat the procedure for negative source voltages with the same magnitudes as those listed in [Table 1-4](#).
7. Repeat the entire procedure using the rear panel INPUT/OUTPUT jacks. Be sure to select the rear panel jacks with the front panel TERMINALS key.

Table 1-4

Voltage measurement accuracy limits

Model 2440 source and measure range*	Source voltage*	Model 2440 voltage reading limits (1 year, 18°C-28°C)
200mV	200.000mV	199.676 to 200.324mV
2V	2.00000V	1.99946 to 2.00054V
10V	10.0000V	9.9978 to 10.0022V
40V	40.0000V	39.991 to 40.009V

* Measure range coupled to source range when simultaneously sourcing and measuring voltage.

** As measured by precision digital multimeter. Use closest possible value, and modify reading limits accordingly if necessary.

Output current accuracy

Follow the steps below to verify that Model 2440 output current accuracy is within specified limits. The test involves setting the output current to each full-range value and measuring the currents with a precision digital multimeter.

10 μ A to 1A range accuracy

1. With the power off, connect the digital multimeter to the Model 2440 INPUT/OUTPUT jacks, as shown in [Figure 1-2](#).

Figure 1-2

Connections for 10 μ A to 1A range current verification tests

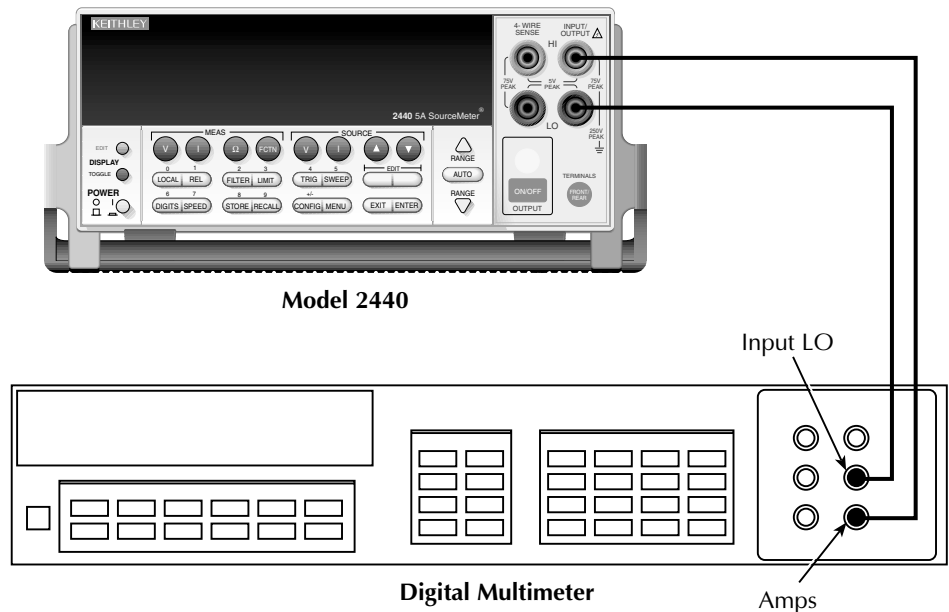

2. Select the multimeter DC current measuring function.
3. Press the Model 2440 SOURCE I key to source current, and make sure the source output is turned on.
4. Verify output current accuracy for the 10 μ A-1A range currents listed in [Table 1-5](#). For each test point:
 - Select the correct source range.
 - Set the Model 2440 output current to the correct value.
 - Verify that the multimeter reading is within the limits given in the table.
5. Repeat the procedure for negative output currents with the same magnitudes as those listed in [Table 1-5](#).
6. Repeat the entire procedure using the rear panel INPUT/OUTPUT jacks. Be sure to select the rear panel jacks with the front panel TERMINALS key.

5A range accuracy

1. With the power off, connect the digital multimeter and the 1Ω resistor to the Model 2440 INPUT/OUTPUT jacks, as shown in [Figure 1-3](#).

Figure 1-3

Connections for 5A range current verification tests

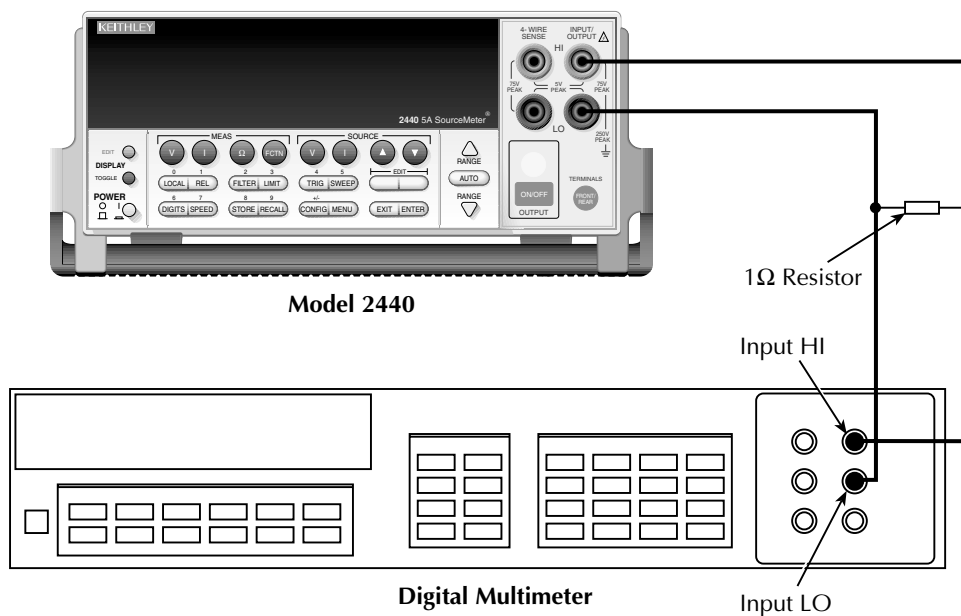

2. Select the multimeter DC volts measuring function.
3. Press the Model 2440 SOURCE I key to source current, and make sure the source output is turned on.
4. Verify output current accuracy for the 5A range. Be sure to:
 - Select the 5A source range.
 - Set the Model 2440 output current to the correct 5A output value.
 - Verify that the multimeter reading is within the 5A range limits given in [Table 1-5](#).

(Since the value of the 1 Ω resistor value is assumed to be the same as its nominal value, the DMM voltage reading is the same as the sourced current.)

5. Repeat the procedure for a negative 5A current output value.
6. Repeat the entire procedure using the rear panel INPUT/OUTPUT jacks. Be sure to select the rear panel jacks with the front panel TERMINALS key.

Table 1-5

Output current accuracy limits

Model 2440 source range	Model 2440 output current setting	Output current limits (1 year, 18°C-28°C)
10 μ A	10.0000 μ A	9.9947 to 10.0053 μ A
100 μ A	100.000 μ A	99.949 to 100.051 μ A
1mA	1.00000mA	0.99946 to 1.00054mA
10mA	10.0000mA	9.9935 to 10.0065mA
100mA	100.000mA	99.914 to 100.086mA
1A	1.00000A	0.99843 to 1.00157A
5A*	5.00000A	4.9896 to 5.0104A

*See separate procedure for 5A range. DMM voltage reading is same as sourced current.

Current measurement accuracy

Follow the steps below to verify that Model 2440 current measurement accuracy is within specified limits. The procedure involves applying accurate currents from the Model 2440 current source and then verifying that Model 2440 current measurements are within required limits.

10 μ A to 1A range accuracy

1. With the power off, connect the digital multimeter to the Model 2440 INPUT/OUTPUT jacks, as shown in [Figure 1-2](#).
2. Select the multimeter DC current function.
3. Set the Model 2440 to both source and measure current by pressing the SOURCE I and MEAS I keys, and make sure the source output is turned on.
4. Verify measure current accuracy for the 10 μ A-1A range currents listed in [Table 1-6](#). For each measurement:
 - Select the correct source range.
 - Set the Model 2440 source output to the correct value as measured by the digital multimeter.
 - Verify that the Model 2440 current reading is within the limits given in the table.

NOTE *It may not be possible to set the current source to the specified value. Use the closest possible setting, and modify reading limits accordingly.*

5. Repeat the procedure for negative calibrator currents with the same magnitudes as those listed in [Table 1-6](#).
6. Repeat the entire procedure using the rear panel INPUT/OUTPUT jacks. Be sure to select the rear panel jacks with the front panel TERMINALS key.

5A range accuracy

NOTE The 1Ω resistor should be characterized to within ±300ppm before verifying the 5A current measurement range. Use the 4-wire ohms function of the DMM to measure the resistance value, and then use that measured value to calculate the current during the measurement procedure.

1. With the power off, connect the 1Ω resistor and digital multimeter to the Model 2440 INPUT/OUTPUT jacks, as shown in Figure 1-3.
2. Select the multimeter DC volts function.
3. Set the Model 2440 to both source and measure current by pressing the SOURCE I and MEAS I keys, and make sure the source output is turned on.
4. Verify measurement current accuracy for the 5A range as follows:
 - Select the 5A source range.
 - Set the Model 2440 source output to the correct 5A value as measured by the digital multimeter.
 - Note the DMM voltage reading, and then calculate the current from the voltage reading and characterized 1Ω resistance value as $I = V/R$, where V is the DMM voltage reading and R is the characterized resistance value.
 - Verify that the Model 2440 current reading is within the 5A limits given in the Table 1-6.

NOTE It may not be possible to set the current source to the specified 5A value. Use the closest possible setting, and modify reading limits accordingly.

5. Repeat the procedure for a negative 5A current.
6. Repeat the procedure using the rear panel INPUT/OUTPUT jacks. Be sure to select the rear panel jacks with the front panel TERMINALS key.

Table 1-6

Current measurement accuracy limits

Model 2440 source and measure range*	Source current**	Model 2440 current reading limits (1 year, 18°C-28°C)
10μA	10.00000μA	9.9966 to 10.0034μA
100μA	100.000μA	99.969 to 100.031μA
1mA	1.00000mA	0.99967 to 1.00033mA
10mA	10.0000mA	9.9959 to 10.0041mA
100mA	100.000mA	99.939 to 100.061mA
1A	1.00000A	0.99883 to 1.00117A
5A	5.00000A	4.9916 to 5.0084A***

* Measure range coupled to source range when simultaneously sourcing and measuring current.

** As measured by precision digital multimeter. Use closest possible value, and modify reading limits accordingly if necessary.

*** Current calculated as follows: $I = V/R$, where V is the DMM voltage reading, and R is the characterized value of the 1Ω resistor.

Resistance measurement accuracy

Use the following steps to verify that Model 2440 resistance measurement accuracy is within specified limits. This procedure involves applying accurate resistances from a resistance calibrator and then verifying that Model 2440 resistance measurements are within required limits.

CAUTION Before testing the 2Ω and 20Ω ranges make sure your resistance calibrator can safely handle the default test currents for those ranges (see Model 2440 and calibrator specifications). If not, use the CONFIG OHMS menu to select the MANUAL source mode, then set the source current to an appropriate safe value. When using the manual source mode, total resistance reading uncertainty includes both Source I and Measure V uncertainty (see specifications), and calculated reading limits should take the additional uncertainty into account.

If using the Fluke 5450A resistance calibrator, you cannot use the Auto Ohms mode of the Model 2440 to verify the 2Ω range. The 1A test current for the 2Ω range of the Model 2440 will damage the calibrator. On the Model 2440, use the CONFIG OHMS menu to select the MANUAL source mode, and then set the source (test) current to 100mA.

1. With the power off, connect the resistance calibrator to the Model 2440 INPUT/OUTPUT and 4-WIRE SENSE jacks, as shown in Figure 1-4. Be sure to use the 4-wire connections as shown.

Figure 1-4

Connections for resistance accuracy verification

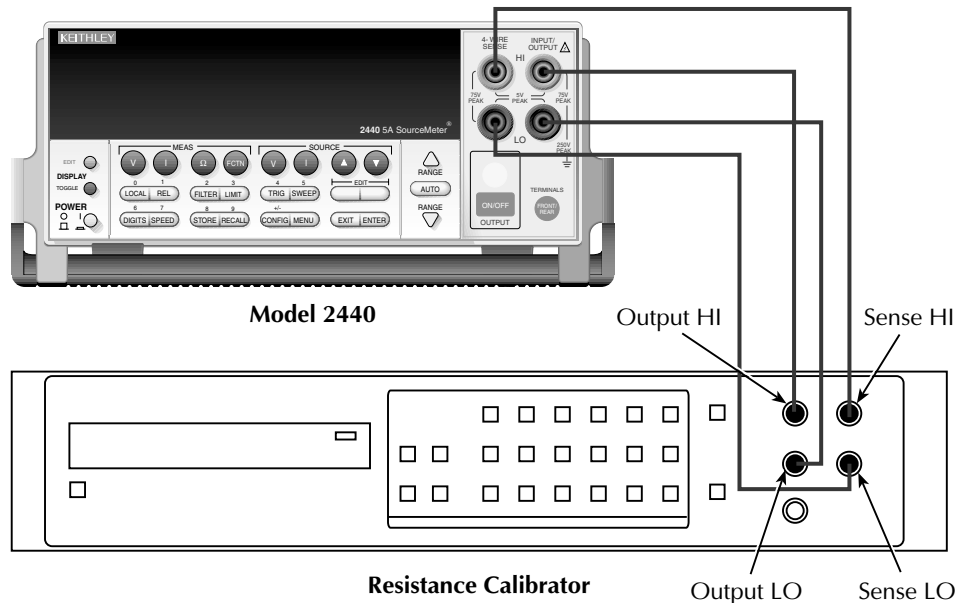

2. Select the resistance calibrator external sense mode.
3. Configure the Model 2440 ohms function for the 4-wire sense mode as follows:
 - Press CONFIG then MEAS Ω . The instrument will display the following:
CONFIG OHMS
SOURCE SENSE-MODE GUARD
 - Select SENSE-MODE, and then press ENTER. The following will be displayed:
SENSE-MODE
2-WIRE 4-WIRE
 - Select 4-WIRE, and then press ENTER.
 - Press EXIT to return to normal display.
4. Press MEAS Ω to select the ohms measurement function, and make sure the source output is turned on.
5. Verify ohms measurement accuracy for each of the resistance values listed in Table 1-7. For each measurement:
 - Set the resistance calibrator output to the nominal resistance or closest available value.

NOTE *It may not be possible to set the resistance calibrator to the specified value. Use the closest possible setting, and modify reading limits accordingly.*

- Select the appropriate ohms measurement range with the RANGE keys.
 - Verify that the Model 2440 resistance reading is within the limits given in the table.
6. Repeat the entire procedure using the rear panel INPUT/OUTPUT and 4-WIRE SENSE jacks. Be sure to select the rear panel jacks with the front panel TERMINALS key.

Table 1-7

Ohms measurement accuracy limits

Model 2440 range	Calibrator resistance*	Model 2440 resistance reading limits** (1 year, 18°C-28°C)
2 Ω	1.9 Ω	1.89647 to 1.90353 Ω
20 Ω	19 Ω	18.9780 to 19.0220 Ω
200 Ω	190 Ω	189.818 to 190.182 Ω
2k Ω	1.9k Ω	1.89837 to 1.90163k Ω
20k Ω	19k Ω	18.9856 to 19.0144k Ω
200k Ω	190k Ω	189.837 to 190.163k Ω
2M Ω	1.9M Ω	1.89761 to 1.90239M Ω
20M Ω	19M Ω	18.9781 to 19.0219M Ω

* Nominal resistance value.

** Reading limits based on Model 2440 normal accuracy specifications and nominal resistance values. If actual resistance values differ from nominal values shown, recalculate reading limits using actual calibrator resistance values and Model 2440 normal accuracy specifications. See Verification limits earlier in this section for details.

2 Calibration

Introduction

Use the procedures in this section to calibrate the Model 2440. These procedures require accurate test equipment to measure precise DC voltages and currents. Calibration can be performed either from the front panel or by sending SCPI calibration commands over the IEEE-488 bus or RS-232 port with the aid of a computer.

WARNING This information in this section is intended for qualified service personnel only. Do not attempt these procedures unless you are qualified to do so. Some of these procedures may expose you to hazardous voltages.

Environmental conditions

Temperature and relative humidity

Conduct the calibration procedures at an ambient temperature of 18-28°C (65-82°F) with relative humidity of less than 70% unless otherwise noted.

Warm-up period

Allow the Model 2440 to warm up for at least one hour before performing calibration.

If the instrument has been subjected to temperature extremes (those outside the ranges stated above), allow additional time for the instrument's internal temperature to stabilize. Typically, allow one extra hour to stabilize a unit that is 10°C (18°F) outside the specified temperature range.

Also, allow the test equipment to warm up for the minimum time specified by the manufacturer.

Line power

The Model 2440 requires a line voltage of 88 to 264V at line frequency of 50 to 60Hz. The instrument must be calibrated while operating from a line voltage within this range.

Calibration considerations

When performing the calibration procedures:

- Make sure that the test equipment is properly warmed up and connected to the Model 2440 front panel INPUT/OUTPUT jacks. Also be certain that the front panel jacks are selected with the TERMINALS switch.
- Always allow the source signal to settle before calibrating each point.
- Do not connect test equipment to the Model 2440 through a scanner or other switching equipment.
- If an error occurs during calibration, the Model 2440 will generate an appropriate error message. See [Appendix B](#) for more information.

WARNING The maximum common-mode voltage (voltage between LO and chassis ground) is 40V peak. Exceeding this value may cause a breakdown in insulation, creating a shock hazard.

CAUTION The maximum voltage between INPUT/OUTPUT HI and LO or 4-WIRE SENSE HI and LO is 42V peak. The maximum voltage between INPUT/OUTPUT HI and 4-WIRE SENSE HI or between INPUT/OUTPUT LO and 4-WIRE SENSE LO is 5V. Exceeding these voltage values may result in instrument damage.

Calibration cycle

Perform calibration at least once a year to ensure the unit meets or exceeds its specifications.

Recommended calibration equipment

Table 2-1 lists the recommended equipment for the calibration procedures. You can use alternate equipment as long that equipment has specifications at least as good as those listed in the table. For optimum calibration accuracy, test equipment specifications should be at least four times better than corresponding Model 2440 specifications.

Table 2-1

Recommended calibration equipment

Description	Manufacturer/Model	Specifications		
Digital Multimeter	Hewlett Packard HP3458A	DC Voltage*	1V:	±5.6ppm
			10V:	±4.3ppm
			100V	±6.3ppm
		DC Current*	10μA:	±25ppm
			100μA:	±23ppm
			1mA:	±20ppm
			10mA:	±20ppm
100mA:	±35ppm			
1A:	±110ppm			
Precision Resistor**	Isotec RUG-Z-1R00-0.1	1Ω, ±0.1%, 100W		

* 90-day, full-range accuracy specifications of ranges required for various measurement points.

** Necessary for calibration of 5A current range. Resistor must be characterized to ±300ppm or better using recommended DMM before calibrating 5A range.

1Ω resistor characterization

The 1Ω resistor must be characterized to ±300ppm or better before calibrating the 5A current range. Use the 4-wire ohms function of the DMM recommended in Table 2-1 to measure the resistance value, and then use that measured value to calculate the current during the 5A current range calibration procedure.

Unlocking calibration

Before performing calibration, you must first unlock calibration by entering or sending the calibration password as explained in the following paragraphs.

Unlocking calibration from the front panel

1. Press the MENU key, and then choose CAL, and press ENTER. The instrument will display the following:
CALIBRATION
UNLOCK EXECUTE VIEW-DATES
◀ SAVE LOCK CHANGE-PASSWORD
2. Select UNLOCK, and then press ENTER. The instrument will display the following:
PASSWORD:
Use ◀ ▶ ▲ ▼, ENTER or EXIT.
3. Use the up and down RANGE keys to select the letter or number, and use the left and right arrow keys to choose the position. (Press down RANGE for letters; up RANGE for numbers.) Enter the present password on the display. (Front panel default: 002440.)
4. Once the correct password is displayed, press the ENTER key. If the password was correctly entered, the following message will be displayed:
CALIBRATION UNLOCKED
Calibration can now be executed.
5. Press EXIT to return to normal display. Calibration will be unlocked and assume the states summarized in [Table 2-2](#). Attempts to change any of the settings listed below with calibration unlocked will result in an error +510, “Not permitted with cal unlocked.”

NOTE With calibration unlocked, the sense function and range track the source function and range. That is, when `:SOUR:FUNC` is set to `VOLT`, the `:SENS:FUNC` setting will be `'VOLT:DC'`. When `:SOUR:FUNC` is set to `CURR`, the `:SENS:FUNC` setting will be `'CURR:DC'`. A similar command coupling exists for `:SOUR:VOLT:RANG:SENS:VOLT:RANG` and `SOUR:CURR:RANG:SENS:CURR:RANG`.

Table 2-2
Calibration unlocked states

Mode	State	Equivalent remote command
Concurrent Functions	OFF	:SENS:FUNC:CONC OFF
Sense Function	Source	:SENS:FUNC <source_function>
Sense Volts NPLC	1.0	:SENS:VOLT:NPLC 1.0
Sense Volts Range	Source V	:SENS:VOLT:RANG <source_V_range>
Sense Current NPLC	1.0	:SENS:CURR:NPLC 1.0
Sense Current Range	Source I	:SENS:CURR:RANG <source_I_range>
Filter Count	10	:SENS:AVER:COUN 10
Filter Control	REPEAT	:SENS:AVER:TCON REPEAT
Filter Averaging	ON	:SENS:AVER:STAT ON
Source V Mode	FIXED	:SOUR:VOLT:MODE FIXED
Volts Autorange	OFF	:SOUR:VOLT:RANG:AUTO OFF
Source I Mode	FIXED	:SOUR:CURR:MODE FIXED
Current Autorange	OFF	:SOUR:CURR:RANG:AUTO OFF
Autozero	ON	:SYST:AZERO ON
Trigger Arm Count	1	:ARM:COUNT 1
Trigger Arm Source	Immediate	:ARM:SOUR IMMEDIATE
Trigger Count	1	:TRIG:COUNT 1
Trigger Source	Immediate	:TRIG:SOUR IMMEDIATE

Unlocking calibration by remote

To unlock calibration via remote, send the following command:

```
:CAL:PROT:CODE '<password>'
```

For example, the following command uses the default password:

```
:CAL:PROT:CODE 'KI002440'
```

Changing the password

The default password may be changed from the front panel or via remote as discussed below.

Changing the password from the front panel

Follow the steps below to change the password from the front panel:

1. Press the MENU key, then choose CAL and press ENTER. The instrument will display the following:
CALIBRATION
UNLOCK EXECUTE VIEW-DATES ►
◀ SAVE LOCK CHANGE-PASSWORD
2. Select UNLOCK, then enter the password. (Default: 002440.)
3. Select CHANGE-PASSWORD, and then press ENTER. The instrument will display the following:
New Pwd: 002440
Use ◀, ▶, ▲, ▼, ENTER or EXIT.
4. Using the range keys, and the left and right arrow keys, enter the new password on the display.
5. Once the desired password is displayed, press the ENTER key to store the new password.

Changing the password by remote

To change the calibration password by remote, first send the present password, and then send the new password. For example, the following command sequence changes the password from the 'KI002440' remote default to 'KI_CAL':

```
:CAL:PROT:CODE 'KI002440'  
:CAL:PROT:CODE 'KI_CAL'
```

You can use any combination of letters and numbers up to a maximum of eight characters.

NOTE *If you change the first two characters of the password to something other than “KI”, you will not be able to unlock calibration from the front panel.*

Resetting the calibration password

If you lose the calibration password, you can unlock calibration by shorting together the CAL pads, which are located on the display board. Doing so will also reset the password to the factory default (KI002440).

See [Section 5](#) for details on disassembling the unit to access the CAL pads. Refer to the display board component layout drawing at the end of [Section 6](#) for the location of the CAL pads.

Viewing calibration dates and calibration count

When calibration is locked, only the UNLOCK and VIEW-DATES selections will be accessible in the calibration menu. To view calibration dates and calibration count at any time:

1. From normal display, press MENU, select CAL, and then press ENTER. The unit will display the following:
CALIBRATION
UNLOCK EXECUTE VIEW-DATES
2. Select VIEW-DATES, and then press ENTER. The Model 2440 will display the next and last calibration dates and the calibration count as in the following example:
NEXT CAL: 02/15/2002
Last calibration: 02/15/2001 Count: 0001

Calibration errors

The Model 2440 checks for errors after each calibration step, minimizing the possibility that improper calibration may occur due to operator error.

Front panel error reporting

If an error is detected during comprehensive calibration, the instrument will display an appropriate error message (see [Appendix B](#)). The unit will then prompt you to repeat the calibration step that caused the error.

Remote error reporting

You can detect errors while in remote by testing the state of EAV (Error Available) bit (bit 2) in the status byte. (Use the *STB? query to request the status byte.) Query the instrument for the type of error by using the appropriate :SYST:ERR? query. The Model 2440 will respond with the error number and a text message describing the nature of the error. See [Appendix B](#) for details.

Front panel calibration

The front panel calibration procedure described below calibrates all ranges of both the current and voltage source and measure functions. Note that each range is separately calibrated by repeating the entire procedure for each range.

Step 1: Prepare the Model 2440 for calibration

1. Turn on the Model 2440 and the digital multimeter, and allow them to warm up for at least one hour before performing calibration.
2. Press the MENU key, then choose CAL and press ENTER. Select UNLOCK, and then press ENTER. The instrument will display the following:
PASSWORD:
Use ◀, ▶, ▲, ▼, ENTER or EXIT.
3. Use the up and down range keys to select the letter or number, and use the left and right arrow keys to choose the position. Enter the present password on the display. (Front panel default: 002440.) Press ENTER to complete the process.
4. Press EXIT to return to normal display. Instrument operating states will be set as summarized in Table 2-2.

Step 2: Voltage calibration

Perform the steps below for each voltage range, using [Table 2-3](#) as a guide.

1. Connect the Model 2440 to the digital multimeter, as shown in [Figure 2-1](#). Select the multimeter DC volts measurement function.

NOTE The 2-wire connections shown assume that remote sensing is not used. Remote sensing may be used, if desired, but it is not essential when using the recommended digital multimeter.

Figure 2-1
Voltage calibration test connections

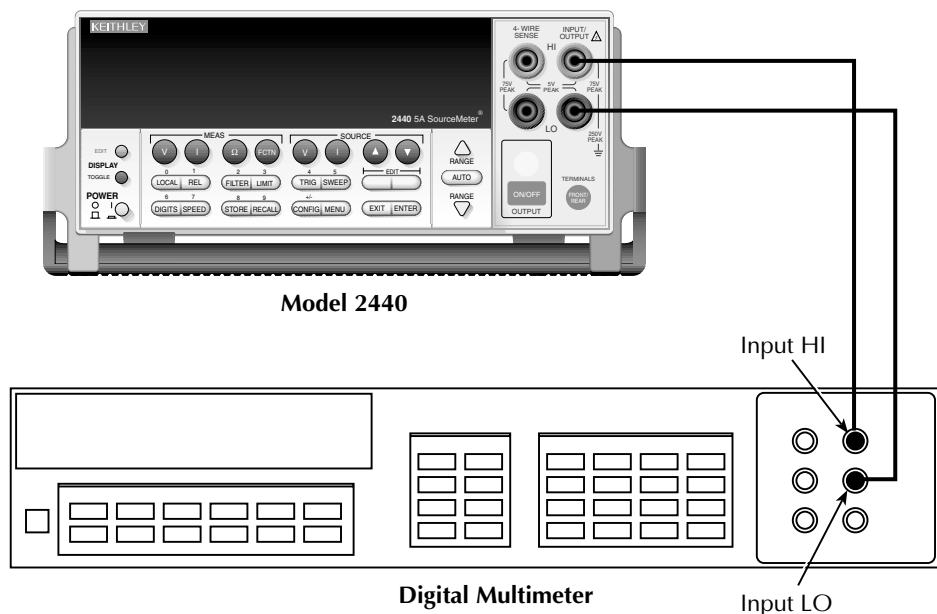

2. From normal display, press the SOURCE V key.
3. Press the EDIT key to select the source field (cursor flashing in source display field), and then use the down RANGE key to select the 200mV source range.
4. From normal display, press MENU.
5. Select CAL, and then press ENTER. The unit will display the following:
 CALIBRATION
 UNLOCK EXECUTE VIEW-DATES ►
 ◀ SAVE LOCK CHANGE-PASSWORD

6. Select EXECUTE, and then press ENTER. The instrument will display the following message:
V-CAL
Press ENTER to Output +200.00mV
7. Press ENTER. The Model 2440 will source +200mV and simultaneously display the following:
DMM RDG: +200.0000mV
Use ◀, ▶, ▲, ▼, ENTER, or EXIT.
8. Note and record the DMM reading, and then adjust the Model 2440 display to agree exactly with the actual DMM reading. Use the up and down arrow keys to select the digit value, and use the left and right arrow keys to choose the digit position (or use the number keys, 0-9, +/-). Note that the display adjustment range is within $\pm 10\%$ of the present range.
9. After adjusting the display to agree with the DMM reading, press ENTER. The instrument will then display the following:
V-CAL
Press ENTER to Output +000.00mV
10. Press ENTER. The Model 2440 will source 0mV and at the same time display the following:
DMM RDG: +000.0000mV
Use ◀, ▶, ▲, ▼, ENTER, or EXIT.
11. Note and record the DMM reading, and then adjust the Model 2440 display to agree with the actual DMM reading. Note that the display value adjustment limits are within $\pm 1\%$ of the present range.
12. After adjusting the display value to agree with the DMM reading, press ENTER. The unit will then display the following:
V-CAL
Press ENTER to Output -200.00mV
13. Press ENTER. The Model 2440 will source -200mV and display the following:
DMM RDG: -200.0000mV
Use ◀, ▶, ▲, ▼, ENTER, or EXIT.
14. Note and record the DMM reading, and then adjust the Model 2440 display to agree with the DMM reading. Again, the maximum display adjustment is within $\pm 10\%$ of the present range.
15. After adjusting the display value to agree with the DMM reading, press ENTER and note that the instrument displays:
V-CAL
Press ENTER to Output -000.00mV
16. Press ENTER. The Model 2440 will source -0mV and simultaneously display the following:
DMM RDG: +000.0000mV
Use ◀, ▶, ▲, ▼, ENTER or EXIT.

17. Note and record the DMM reading, and then adjust the display to agree with the DMM reading. Once again, the maximum adjustment is within $\pm 1\%$ of the present range.
18. After adjusting the display to agree with the DMM reading, press ENTER to complete calibration of the present range.
19. Press EXIT to return to normal display, and then select the 2V source range. Repeat steps 2 through 18 for the 2V range.
20. After calibrating the 2V range, repeat the entire procedure for the 10V and 40V ranges using Table 2-3 as a guide. Be sure to select the appropriate source range with the EDIT and RANGE keys before calibrating each range.
21. Press EXIT as necessary to return to normal display.

Table 2-3

Front panel voltage calibration

Source range*	Source voltage	Multimeter voltage reading**
0.2V	+200.00mV	_____ mV
	+000.00mV	_____ mV
	-200.00mV	_____ mV
	-000.00mV	_____ mV
2V	+2.0000V	_____ V
	+0.0000V	_____ V
	-2.0000V	_____ V
	-0.0000V	_____ V
10V	+10.000V	_____ V
	+00.000V	_____ V
	-10.000V	_____ V
	-00.000V	_____ V
40V	+40.000V	_____ V
	+00.000V	_____ V
	-40.000V	_____ V
	-00.000V	_____ V

*Use EDIT and RANGE keys to select source range.

**Multimeter reading used in corresponding calibration step. See procedure.

Step 3: Current calibration

Perform the steps below for each current range, using [Table 2-4](#) as a guide.

1. Connect the Model 2440 to the digital multimeter, as shown in [Figure 2-2](#). Select the multimeter DC current measurement function.

Figure 2-2

10 μ A to 1A range current calibration test connections

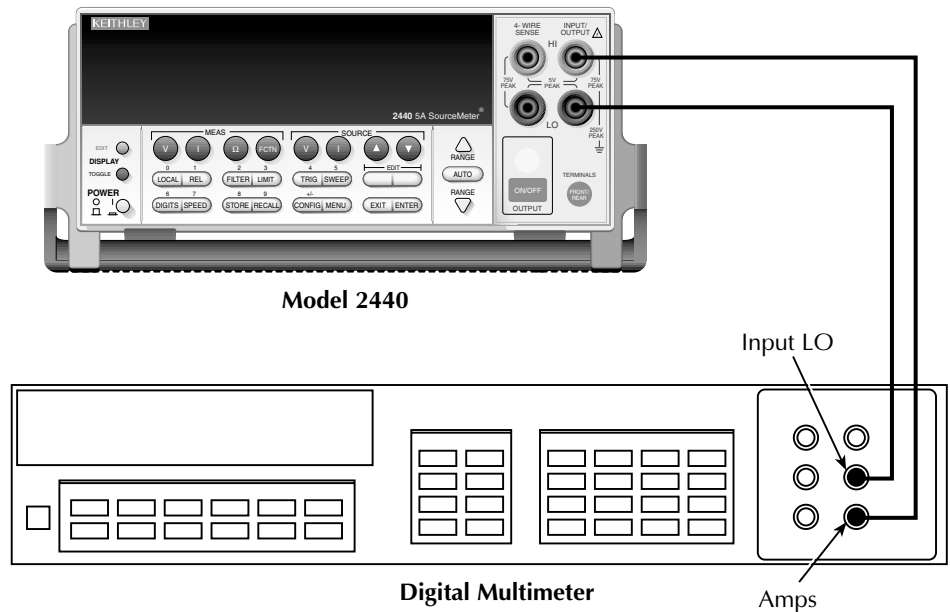

2. From normal display, press the SOURCE I key.
3. Press the EDIT key to select the source display field, and then use the down RANGE key to select the 10 μ A source range.
4. From normal display, press MENU.
5. Select CAL, and then press ENTER. The unit will display the following:

```
CALIBRATION
UNLOCK EXECUTE VIEW-DATES ►
◀ SAVE LOCK CHANGE-PASSWORD
```
6. Select EXECUTE, and then press ENTER. The instrument will display the following message:

```
I-CAL
Press ENTER to Output +10.000 $\mu$ A
```

7. Press ENTER. The Model 2440 will source +10 μ A and simultaneously display the following:
DMM RDG: +10.00000 μ A
Use ◀, ▶, ▲, ▼, ENTER, or EXIT.
8. Note and record the DMM reading, and then adjust the Model 2440 display to agree exactly with the actual DMM reading. Use the up and down arrow keys to select the digit value, and use the left and right arrow keys to choose the digit position (or use the number keys, 0-9, +/-). Note that the display adjustment range is within $\pm 10\%$ of the present range.
9. After adjusting the display to agree with the DMM reading, press ENTER. The instrument will then display the following:
I-CAL
Press ENTER to Output +00.000 μ A
10. Press ENTER. The Model 2440 will source 0mA and at the same time display the following:
DMM RDG: +00.00000 μ A
Use ◀, ▶, ▲, ▼, ENTER, or EXIT.
11. Note and record the DMM reading, and then adjust the Model 2440 display to agree with the actual DMM reading. Note that the display value adjustment limits are within $\pm 1\%$ of the present range.
12. After adjusting the display value to agree with the DMM reading, press ENTER. The unit will then display the following:
I-CAL
Press ENTER to Output -10.000 μ A
13. Press ENTER. The Model 2440 will source -10 μ A and display the following:
DMM RDG: -10.00000 μ A
Use ◀, ▶, ▲, ▼, ENTER, or EXIT.
14. Note and record the DMM reading, and then adjust the Model 2440 display to agree with the DMM reading. Again, the maximum display adjustment is within $\pm 10\%$ of the present range.
15. After adjusting the display value to agree with the DMM reading, press ENTER and note that the instrument displays:
I-CAL
Press ENTER to Output -00.000 μ A
16. Press ENTER. The Model 2440 will source -0 μ A and simultaneously display the following:
DMM RDG: +00.00000 μ A
Use ◀, ▶, ▲, ▼, ENTER, or EXIT.
17. Note and record the DMM reading, and then adjust the display to agree with the DMM reading. Once again, the maximum adjustment is within $\pm 1\%$ of the present range.

18. After adjusting the display to agree with the DMM reading, press ENTER to complete calibration of the present range.
19. Press EXIT to return to normal display, and then select the 100 μ A source range use the EDIT and up RANGE keys. Repeat steps 2 through 18 for the 100 μ A range.
20. After calibrating the 100 μ A range, repeat the entire procedure for the 1mA through 1A ranges using Table 2-4 as a guide. Be sure to select the appropriate source range with the EDIT and up RANGE keys before calibrating each range.
21. After calibrating the 1A range, connect the 1 Ω characterized resistor and DMM to the Model 2440 INPUT/OUTPUT jacks, as shown in Figure 2-3.
22. Select the DMM DC volts function.
23. Repeat steps 2 through 18 for the 5A range using Table 2-4 as a guide. When entering the DMM reading, use the calculated current as follows: $I = V/R$, where V is the DMM voltage reading, and R is the characterized value of the 1 Ω resistor.

Figure 2-3
5A range current calibration test connections

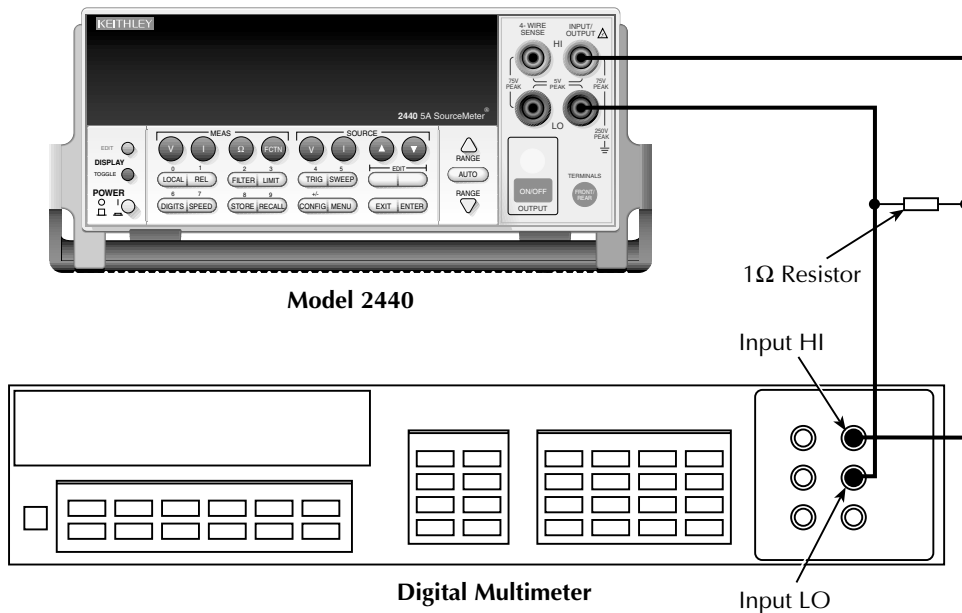

Table 2-4
Front panel current calibration

Source range*	Source current	Multimeter current reading**
10μA	+10.000μA	_____ μA
	+00.000μA	_____ μA
	-10.000μA	_____ μA
	-00.000μA	_____ μA
100μA	+100.00μA	_____ μA
	+000.00μA	_____ μA
	-100.00μA	_____ μA
	-000.00μA	_____ μA
1mA	+1.0000mA	_____ mA
	+0.0000mA	_____ mA
	-1.0000mA	_____ mA
	-0.0000mA	_____ mA
10mA	+10.000mA	_____ mA
	+00.000mA	_____ mA
	-10.000mA	_____ mA
	-00.000mA	_____ mA
100mA	+100.00mA	_____ mA
	+000.00mA	_____ mA
	-100.00mA	_____ mA
	-000.00mA	_____ mA
1A	+1.0000A	_____ A
	+0.0000A	_____ A
	-1.0000A	_____ A
	-0.0000A	_____ A
5A***	+5.0000A	_____ A
	+0.0000A	_____ A
	-5.0000A	_____ A
	-0.0000A	_____ A

* Use EDIT and RANGE keys to select source range.

** Multimeter reading used in corresponding calibration step. See procedure.

*** Current calculated as follows: $I = V/R$, where V is the DMM reading, and R is the characterized value of the 1Ω resistor.

Step 4: Enter calibration dates and save calibration

NOTE For temporary calibration without saving new calibration constants, proceed to “Step 5: Lock out calibration”.

1. From normal display, press MENU.
2. Select CAL, and then press ENTER. The Model 2440 will display the following:
CALIBRATION
UNLOCK EXECUTE VIEW-DATES ►
◀ SAVE LOCK CHANGE-PASSWORD
3. Select SAVE, and then press ENTER. The instrument will display the following message:
SAVE CAL
Press ENTER to continue; EXIT to abort calibration sequence.
4. Press ENTER. The unit will prompt you for the calibration date:
CAL DATE: 2/15/2001
Use ◀, ▶, ▲, ▼, ENTER, or EXIT.
5. Change the displayed date to today's date, and then press the ENTER key. Press ENTER again to confirm the date.
6. The unit will then prompt for the calibration due date:
NEXT CAL: 2/15/2002
Use ◀, ▶, ▲, ▼, ENTER, or EXIT.
7. Set the calibration due date to the desired value, and then press ENTER. Press ENTER again to confirm the date.
8. Once the calibration dates are entered, calibration is complete, and the following message will be displayed:
CALIBRATION COMPLETE
Press ENTER to confirm; EXIT to abort
9. Press ENTER to save the calibration data (or press EXIT to abort without saving calibration data.) The following message will be displayed:
CALIBRATION SUCCESS
Press ENTER or EXIT to continue.
10. Press ENTER or EXIT to complete process.

Step 5: Lock out calibration

1. From normal display, press MENU.
2. Select CAL, and then press ENTER. The Model 2440 will display the following:
CALIBRATION
UNLOCK EXECUTE VIEW-DATES ►
◀ SAVE LOCK CHANGE-PASSWORD
3. Select LOCK, and then press ENTER. The instrument will display the following message:
CALIBRATION LOCKED.
Press ENTER or EXIT to continue.
4. Press ENTER or EXIT to return to normal display.

Remote calibration

Use the following procedure to perform remote calibration by sending SCPI commands over the IEEE-488 bus or RS-232 port. The remote commands and appropriate parameters are separately summarized for each step.

Remote calibration commands

Table 2-5 summarizes remote calibration commands. For a more complete description of these commands, refer to [Appendix B](#).

Table 2-5

Remote calibration command summary

Command	Description
:CALibration	Calibration subsystem.
:PROTected	Cal commands protected by password.
:CODE '<password>'	Unlock cal; changes password if cal is already unlocked. (Default password: KI002440.)
:COUNT?	Query number of times 2440 has been calibrated.
:SAVE	Save calibration data to EEPROM.*
:LOCK	Lock calibration, inhibit SAVE command operation.
:LOCK?	Request cal lock status.
:DATE <y>,<m>,<d>	Program calibration year, month, day.
:DATE?	Query calibration year, month, day.
:NDUE <y>,<m>,<d>	Program calibration due year, month, day.
:NDUE?	Query calibration due year, month, day.
:SENSe <nrf>	Calibrate active measure range. (See Table 2-6 parameters.)
:DATA?	Query measurement cal constants for active range.
:SOURce <nrf>	Calibrate active source range. (See Table 2-7 parameters.)
:DATA?	Query source cal constants for active range.

* Calibration data will not be saved if:

1. Calibration was not unlocked with :CODE command.
2. Invalid data exists. (For example, cal step failed or was aborted.)
3. Incomplete number of cal steps were performed. (For example, omitting a negative full-scale step).
Ranges that calibrated successfully will be saved if calibration is unlocked. Ranges that failed will not be saved.

Recommended calibration parameters

The maximum calibration command parameter ranges are: 75% to 150% of full scale for positive and negative full scale calibration points; \pm zero calibration steps have $\pm 50\%$ of full scale for valid entry ranges. However, for optimum calibration, it is recommended that you use calibration points within the ranges listed in [Table 2-6](#) and [Table 2-7](#). Note that each sense range requires three parameters: zero, negative full scale, and positive full scale. Similarly, each source range requires four parameters: two zero parameters, a positive full-scale parameter, and a negative full-scale parameter.

Table 2-6

Recommended :CALibration:PROTECTED:SENse parameter ranges

Sense range	First parameter (zero)	Second parameter (negative full scale)	Third parameter (positive full scale)
0.2V	-0.002 to +0.002	-0.18 to -0.22	+0.18 to +0.22
2V	-0.02 to +0.02	-1.8 to -2.2	+1.8 to +2.2
10V	-0.1 to +0.1	-9 to -11	+9 to +11
40V	-0.5 to +0.5	-35 to -42	+35 to +42
10 μ A	-1E-7 to +1E-7	-9E-6 to -11E-6	+9E-6 to +11E-6
100 μ A	-1E-6 to +1E-6	-90E-6 to -110E-6	+90E-6 to +110E-6
1mA	-1E-5 to +1E-5	-0.9E-3 to -1.1E-3	+0.9E-3 to +1.1E-3
10mA	-1E-4 to +1E-4	-9E-3 to -11E-3	+9E-3 to +11E-3
100mA	-1E-3 to +1E-3	-90E-3 to -110E-3	+90E-3 to +110E-3
1A	-1E-2 to +1E-2	-0.9 to -1.1	+0.9 to +1.1
5A	-5E-2 to +5E-2	-4.75 to -5.25	+4.75 to +5.25

Note: Parameter steps for each range may be performed in any order, but all three parameter steps for each range must be completed. For optimum calibration, use parameters within recommended limits.

Table 2-7

Recommended :CALibration:PROTECTED:SOURce parameter ranges

Source range	Second parameter (negative full scale)	Second parameter (negative zero)	Third parameter (positive full scale)	Fourth parameter (positive zero)
0.2V	-0.18 to -0.22	-0.002 to +0.002	+0.18 to +0.22	-0.002 to +0.002
2V	-1.8 to -2.2	-0.02 to +0.02	+1.8 to +2.2	-0.02 to +0.02
10V	-9 to -11	-0.1 to +0.1	+9 to +11	-0.1 to +0.1
40V	-35 to -42	-0.5 to +0.5	+35 to +42	-0.5 to +0.5
10 μ A	-9E-6 to -11E-6	-1E-7 to +1E-7	+9E-6 to +11E-6	-1E-7 to +1E-7
100 μ A	-90E-6 to -110E-6	-1E-6 to +1E-6	+90E-6 to +110E-6	-1E-6 to +1E-6
1mA	-0.9E-3 to -1.1E-3	-1E-5 to +1E-5	+0.9E-3 to +1.1E-3	-1E-5 to +1E-5
10mA	-9E-3 to -1E-3	-1E-4 to +1E-4	+9E-3 to +11E-3	-1E-4 to +1E-4
100mA	-90E-3 to -110E-3	-1E-3 to +1E-3	+90E-3 to +110E-3	-1E-3 to +1E-3
1A	-0.9 to -1.1	-1E-2 to +1E-2	+0.9 to +1.1	-1E-2 to +1E-2
5A	-4.75 to -5.25	-5E-2 to +5E-2	+4.75 to +5.25	-5E-2 to +5E-2

Note: Parameter steps for each range may be performed in any order, but all four parameter steps for each range must be completed. For optimum calibration, use parameters within recommended limits.

Remote calibration procedure

Step 1: Prepare the Model 2440 for calibration

1. Connect the Model 2440 to the controller IEEE-488 interface or RS-232 port using a shielded interface cable.
2. Turn on the Model 2440 and the test equipment, and allow them to warm up for at least one hour before performing calibration.
3. If you are using the IEEE-488 interface, make sure the primary address of the Model 2440 is the same as the address specified in the program you will be using to send commands. (Use the MENU key and the COMMUNICATION menu to access the IEEE-488 address.)

Step 2: Voltage calibration

1. Connect the Model 2440 to the digital multimeter (see [Figure 2-1](#)), and select the multimeter DC volts function.
2. Send the commands summarized in [Table 2-8](#) in the order listed to initialize voltage calibration. (When the :CAL:PROT:CODE command is sent, the instrument will assume the operating states listed in [Table 2-2](#).)
3. Perform the range calibration steps listed in [Table 2-9](#) for all ranges. For each range:
 - Send the :SOUR:VOLT:RANG command to select the source and sense range being calibrated. For example, for the 2V range, the following command would be sent:
:SOUR:VOLT:RANG 2
 - Program the source to output the negative full-range value using the :SOUR:VOLT command. For example:
:SOUR:VOLT -2
 - Note and record the multimeter reading.
 - Use the multimeter reading as the parameter for the :CAL:PROT:SOUR and :CAL:PROT:SENS commands. For example, a typical value for the 2V range would be:
:CAL:PROT:SOUR -1.998
:CAL:PROT:SENS -1.998
 - Program the voltage source for 0V output using the :SOUR:VOLT 0.0 command.
 - Note the multimeter reading.
 - Send the source and sense calibration commands using the multimeter reading for the parameter. For example:
:CAL:PROT:SOUR 1E-3
:CAL:PROT:SENS 1E-3
 - Set the source to the positive full-range value using the :SOUR:VOLT command. For example:
:SOUR:VOLT 2
 - Note and record the multimeter reading.
 - Send the source and sense commands using the multimeter reading as the parameter. For example:
:CAL:PROT:SOUR 1.997
:CAL:PROT:SENS 1.997
 - Send the SOUR:VOLT 0.0 command to set the source voltage to 0V.
 - Note and record the multimeter reading.
 - Send the :CAL:PROT:SOUR command using the multimeter reading as the command parameter. For example:
:CAL:PROT:SOUR -1.02E-3

Table 2-8
Voltage calibration initialization commands

Command	Description
*RST	Restore GPIB defaults.
:SOUR:FUNC VOLT	Activate voltage source.
:SENS:CURR:PROT 0.1	Current limit when voltage source is active.
:SENS:CURR:RANG 0.1	Make sure 1A range is not active.
:SOUR:VOLT:PROT MAX	Maximum allowable source voltage.
:SYST:RSEN OFF	Disable remote sensing.*
:CAL:PROT:CODE 'KI002440'	Unlock cal.
:OUTP:STAT ON	Turn source on.

*Remote sensing may be used if desired, but is not essential when using the recommended digital multimeter. To use remote sensing, send :SYST:RSEN ON.

Table 2-9
Voltage range calibration commands

Step	Command/procedure*	Description
1	:SOUR:VOLT:RANGE <Range>	Select source range.
2	:SOUR:VOLT -<Source_value>	Establish negative full-range polarity.
3	Take DMM reading.	Read actual output value.
4	:CAL:PROT:SOUR <DMM_Reading>	Calibrate sense function negative full scale.
5	Check 2440 for errors.	
6	:CAL:PROT:SENS <DMM_Reading>	Calibrate source function negative full scale.
7	Check 2440 for errors.	
8	:SOUR:VOLT 0.0	Set output to 0V.
9	Take DMM reading.	Read actual output value.
10	:CAL:PROT:SOUR <DMM_Reading>	Calibrate sense function negative zero.
11	Check 2440 for errors.	
12	:CAL:PROT:SENS <DMM_Reading>	Calibration source function negative zero.
13	Check 2440 for errors.	
14	:SOUR:VOLT +<Source_value>	Establish positive full-range polarity.
15	Take DMM reading.	Read actual output value
16	:CAL:PROT:SOUR <DMM_Reading>	Calibrate sense function positive full scale.
17	Check 2440 for errors.	
18	:CAL:PROT:SENS <DMM_Reading>	Calibrate source function positive full scale.
19	Check 2440 for errors.	
20	:SOUR:VOLT 0.0	Set output to 0V.
21	Take DMM reading.	Read actual output value.
22	:CAL:PROT:SOUR <DMM_Reading>	Calibrate source positive zero.

- *1. Perform complete procedure for each range, where <Range> = 0.2, 2, 10, and 40, and <Source_value> = 0.2, 2, 10, and 40.
2. <DMM_Reading> parameter is multimeter reading from previous step.
3. Use :SYST:ERR? query to check for errors.

Step 3: Current calibration

1. Connect the Model 2440 to the digital multimeter (see [Figure 2-2](#)), and select the multimeter DC current function.
2. Send the commands summarized in [Table 2-10](#) in the order listed to initialize current calibration.
3. Calibrate the 10 μ A to 1A current ranges using the procedure summarized in [Table 2-11](#). For each range:
 - Send the :SOUR:CURR:RANG command to select the source and sense range being calibrated. For example, for the 1mA range, the command is:
:SOUR:CURR:RANG 1E-3
 - Program the source to output the negative full-range value using the :SOUR:CURR command. For example:
:SOUR:CURR -1E-3
 - Note and record the multimeter reading.
 - Use the multimeter reading as the parameter for the :CAL:PROT:SOUR and :CAL:PROT:SENS commands. For example, a typical value for the 1mA range would be:
:CAL:PROT:SOUR -1.025E-3
:CAL:PROT:SENS -1.025E-3
 - Program the current source for 0A output using the :SOUR:CURR 0.0 command.
 - Note the multimeter reading.
 - Send the source and sense calibration commands using the multimeter reading for the parameter. For example:
:CAL:PROT:SOUR 1E-6
:CAL:PROT:SENS 1E-6
 - Set the source to the positive full-range value using the :SOUR:CURR command. For example, for the 1mA range:
:SOUR:CURR 1E-3
 - Note and record the multimeter reading.
 - Send the source and sense commands using the multimeter reading as the parameter. For example:
:CAL:PROT:SOUR 1.03E-3
:CAL:PROT:SENS 1.03E-3
 - Send the :SOUR:CURR 0.0 command to set the source current to 0A.
 - Note and record the multimeter reading.
 - Send the :CAL:PROT:SOUR command using the multimeter reading as the command parameter. For example:
:CAL:PROT:SOUR 1E-6

4. Connect the 1Ω resistor and DMM to the Model 2440 INPUT/OUTPUT jacks, as shown in Figure 2-3. Select the DMM DC volts function.
5. Repeat step 3 for the 5A range using the calculated current as follows: $I = V/R$, where V is the DMM voltage reading, and R is the characterized value of the 1Ω resistor.

Table 2-10

Current calibration initialization commands

Command	Description
:SOUR:FUNC CURR	Select source current mode.
:SENS:VOLT:PROT 10	Voltage limit when current source is active.
:SENS:VOLT:RANG 10	Make sure 40V range is not active.
:OUTP:STAT ON	Turn source on.

Table 2-11

Current range calibration commands

Step	Command/procedure*	Description
1	:SOUR:CURR:RANGE <Range>	Select source range.
2	:SOUR:CURR -<Source_value>	Establish negative full-range polarity.
3	Take DMM reading.	Read actual output value.
4	:CAL:PROT:SOUR <DMM_Reading>	Calibrate sense function negative full scale.
5	Check 2440 for errors.	
6	:CAL:PROT:SENS <DMM_Reading>	Calibrate source function negative full scale.
7	Check 2440 for errors.	
8	:SOUR:CURR 0.0	Set output to 0A.
9	Take DMM reading.	Read actual output value.
10	:CAL:PROT:SOUR <DMM_Reading>	Calibrate sense function negative zero.
11	Check 2440 for errors.	
12	:CAL:PROT:SENS <DMM_Reading>	Calibration source function negative zero.
13	Check 2440 for errors.	
14	:SOUR:CURR +<Source_value>	Establish positive full-range polarity.
15	Take DMM reading.	Read actual output value.
16	:CAL:PROT:SOUR <DMM_Reading>	Calibrate sense function positive full scale.
17	Check 2440 for errors.	
18	:CAL:PROT:SENS <DMM_Reading>	Calibrate source function positive full scale.
19	Check 2440 for errors.	
20	:SOUR:CURR 0.0	Set output to 0A.
21	Take DMM reading.	Read actual output value.
22	:CAL:PROT:SOUR <DMM_Reading>	Calibrate source positive zero.

- *1. Perform complete procedure for each range, where <Range> and <Source_value> = 10E-6, 100E-6, 1E-3, 10E-3, 100E-3, 1, or 5.
2. <DMM_Reading> parameter is multimeter reading from previous step.
3. Use :SYST:ERR? query to check for errors.

Step 4: Program calibration dates

Use following commands to set the calibration date and calibration due date:

:CAL:PROT:DATE <year>, <month>, <day> (Calibration date)

:CAL:PROT:NDUE <year>, <month>, <day> (Next calibration due date)

Note that the year, month, and date must be separated by commas.

Step 5: Save calibration constants

Calibration is now complete, so you can store the calibration constants in EEROM by sending the following command:

:CAL:PROT:SAVE

NOTE Calibration will be temporary unless you send the SAVE command. Also, calibration data will not be saved if (1) calibration is locked, (2) invalid data exists, or (3) all steps were not completed.

Step 6: Lock out calibration

To lock out further calibration, send the following command after completing the calibration procedure:

:CAL:PROT:LOCK

Single-range calibration

Normally, the complete calibration procedure should be performed to ensure that the entire instrument is properly calibrated. In some instances, however, you may want to calibrate only certain ranges. To do so, complete the entire procedure only for the range(s) to be calibrated. Keep in mind, however, that you must complete all parameter steps for each source or sense range. Also be sure to set calibration dates and save calibration after calibrating the desired range(s).

3

Routine Maintenance

Introduction

The information in this section deals with routine type maintenance that can be performed by the operator.

Line fuse replacement

WARNING Disconnect the line cord at the rear panel, and remove all test leads connected to the instrument (front and rear) before replacing the line fuse.

The power line fuse is accessible from the rear panel, just above the AC power receptacle (see Figure 3-1).

Figure 3-1
Rear panel

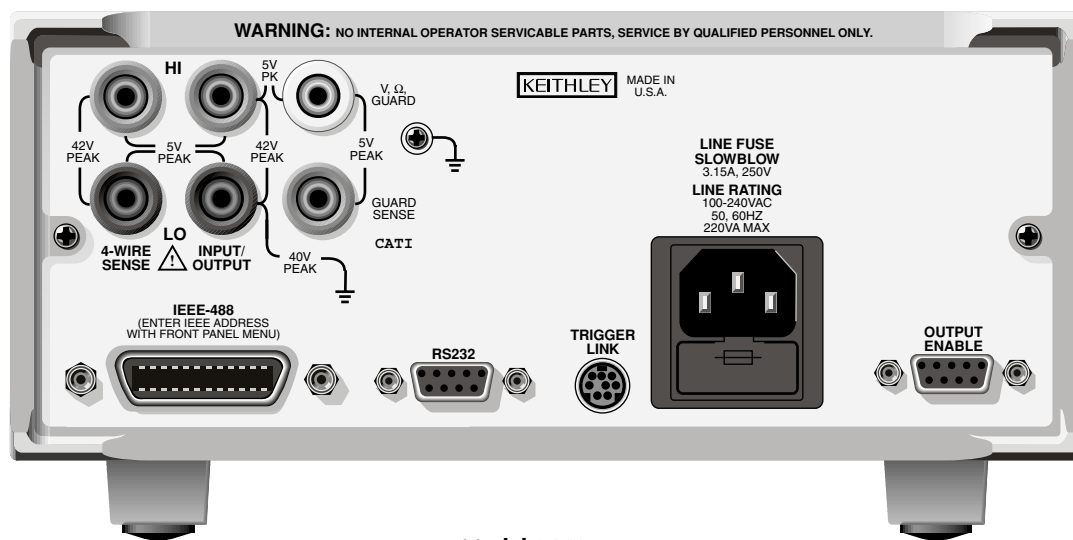

Perform the following steps to replace the line fuse:

1. Carefully grasp and squeeze together the locking tabs that secure the fuse carrier to the fuse holder.
2. Pull out the fuse carrier, and replace the fuse with the type specified in Table 3-1.

CAUTION To prevent instrument damage, use only the fuse type specified in Table 3-1.

3. Reinstall the fuse carrier.

NOTE If the power line fuse continues to blow, a circuit malfunction exists and must be corrected. Refer to the troubleshooting section of this manual for additional information.

Table 3-1
Power line fuse

Line voltage	Rating	Keithley part no.
88-264V	250V, 3.15A, Slow Blow 5 × 20mm	FU-106-3.15

4 Troubleshooting

Introduction

This section of the manual will assist you in troubleshooting and repairing the Model 2440. Included are self-tests, test procedures, troubleshooting tables, and circuit descriptions. Note that disassembly instructions are located in [Section 5](#), and component layout drawings are at the end of [Section 6](#).

WARNING The information in this section is intended for qualified service personnel only. Do not perform these procedures unless you are qualified to do so. Some of these procedures may expose you to hazardous voltages that could cause personal injury or death. Use caution when working with hazardous voltages.

Repair considerations

Before making any repairs to the Model 2440, be sure to read the following considerations.

CAUTION The PC-boards are built using surface mount techniques and require specialized equipment and skills for repair. If you are not equipped and/or qualified, it is strongly recommended that you send the unit back to the factory for repairs or limit repairs to the PC-board replacement level. Without proper equipment and training, you could damage a PC-board beyond repair.

- Repairs will require various degrees of disassembly. However, it is recommended that the Front Panel Tests be performed prior to any disassembly. The disassembly instructions for the Model 2440 are contained in [Section 5](#) of this manual.
- Do not make repairs to surface mount PC-boards unless equipped and qualified to do so (see previous CAUTION).
- When working inside the unit and replacing parts, be sure to adhere to the handling precautions and cleaning procedures explained in [Section 5](#).
- Many CMOS devices are installed in the Model 2440. These static-sensitive devices require special handling as explained in [Section 5](#).
- Whenever a circuit board is removed or a component is replaced, the Model 2440 must be recalibrated. See [Section 2](#) for details on calibrating the unit.

Power-on self-test

During the power-on sequence, the Model 2440 will perform a checksum test on its EPROM and test its RAM. If one of these tests fails, the instrument will lock up.

Front panel tests

There are three front panel tests: one to test the functionality of the front panel keys and two to test the display. In the event of a test failure, refer to “[Display board checks](#)” for details on troubleshooting the display board.

KEYS test

The KEYS test lets you check the functionality of each front panel key. Perform the following steps to run the KEYS test.

1. Display the MAIN MENU by pressing the MENU key.
2. Select TEST, and press ENTER to display the SELF-TEST MENU.
3. Select DISPLAY-TESTS, and press ENTER to display the following menu:
FRONT PANEL TESTS
KEYS DISPLAY-PATTERNS CHAR-SET
4. Select KEYS, and press ENTER to start the test. When a key is pressed, the label name for that key will be displayed to indicate that it is functioning properly. When the key is released, the message “No keys pressed” is displayed.
5. Pressing EXIT tests the EXIT key. However, the second consecutive press of EXIT aborts the test and returns the instrument to the SELF-TEST MENU. Continue pressing EXIT to back out of the menu structure.

DISPLAY PATTERNS test

The display test lets you verify that each pixel and annunciator in the vacuum fluorescent display is working properly. Perform the following steps to run the display test:

1. Display the MAIN MENU by pressing the MENU key.
2. Select TEST, and press ENTER to display the SELF-TEST MENU.
3. Select DISPLAY-TESTS, and press ENTER to display the following menu:
FRONT PANEL TESTS
KEYS DISPLAY-PATTERNS CHAR-SET
4. Select DISPLAY-PATTERNS, and press ENTER to start the display test. There are five parts to the display test. Each time a front panel key (except EXIT) is pressed, the next part of the test sequence is selected. The five parts of the test sequence are as follows:
 - Checkerboard pattern (alternate pixels on) and all annunciators.
 - Checkerboard pattern and the annunciators that are on during normal operation.
 - Horizontal lines (pixels) of the first digit are sequenced.
 - Vertical lines (pixels) of the first digit are sequenced.
 - Each digit (and adjacent annunciator) is sequenced. All the pixels of the selected digit are on.
5. When finished, abort the display test by pressing EXIT. The instrument returns to the FRONT PANEL TESTS MENU. Continue pressing EXIT to back out of the menu structure.

CHAR SET test

The character set test lets you display all characters. Perform the following steps to run the character set test:

1. Display the MAIN MENU by pressing the MENU key.
2. Select TEST, and press ENTER to display the SELF-TEST MENU.
3. Select DISPLAY-TESTS, and press ENTER to display the following menu:
FRONT PANEL TESTS
KEYS DISPLAY-PATTERNS CHAR-SET
4. Select CHAR-SET, and press ENTER to start the character set test. Press any key except EXIT to cycle through all displayable characters.
5. When finished, abort the character set test by pressing EXIT. The instrument returns to the FRONT PANEL TESTS MENU. Continue pressing EXIT to back out of the menu structure.

Principles of operation

The following information is provided to support the troubleshooting tests and procedures covered in this section of the manual. Refer to the following drawings:

Figure 4-1 — Overall block diagram

Figure 4-2 — Analog circuitry block diagram

Figure 4-3 — Power supply block diagram

Figure 4-4 — Output stage simplified schematic

Figure 4-5 — Digital circuitry block diagram

Overall block diagram

Figure 4-1 shows an overall block diagram of the Model 2440. Circuitry may be divided into three general areas:

- Analog circuits — includes sourcing circuits such as the DACs, clamps, output stage, and feedback circuits, as well as measurement circuits such as the A/D converter.
- Digital circuits — includes the microcomputer that controls the analog section, front panel, and GPIB and RS-232 ports, as well as associated interfacing circuits.
- Power supplies — converts the AC line voltage into DC voltages that supply the power for the digital and analog circuits, and the output stage.

Analog circuits

Figure 4-2 shows the analog circuitry block.

Figure 4-1
Overall block diagram

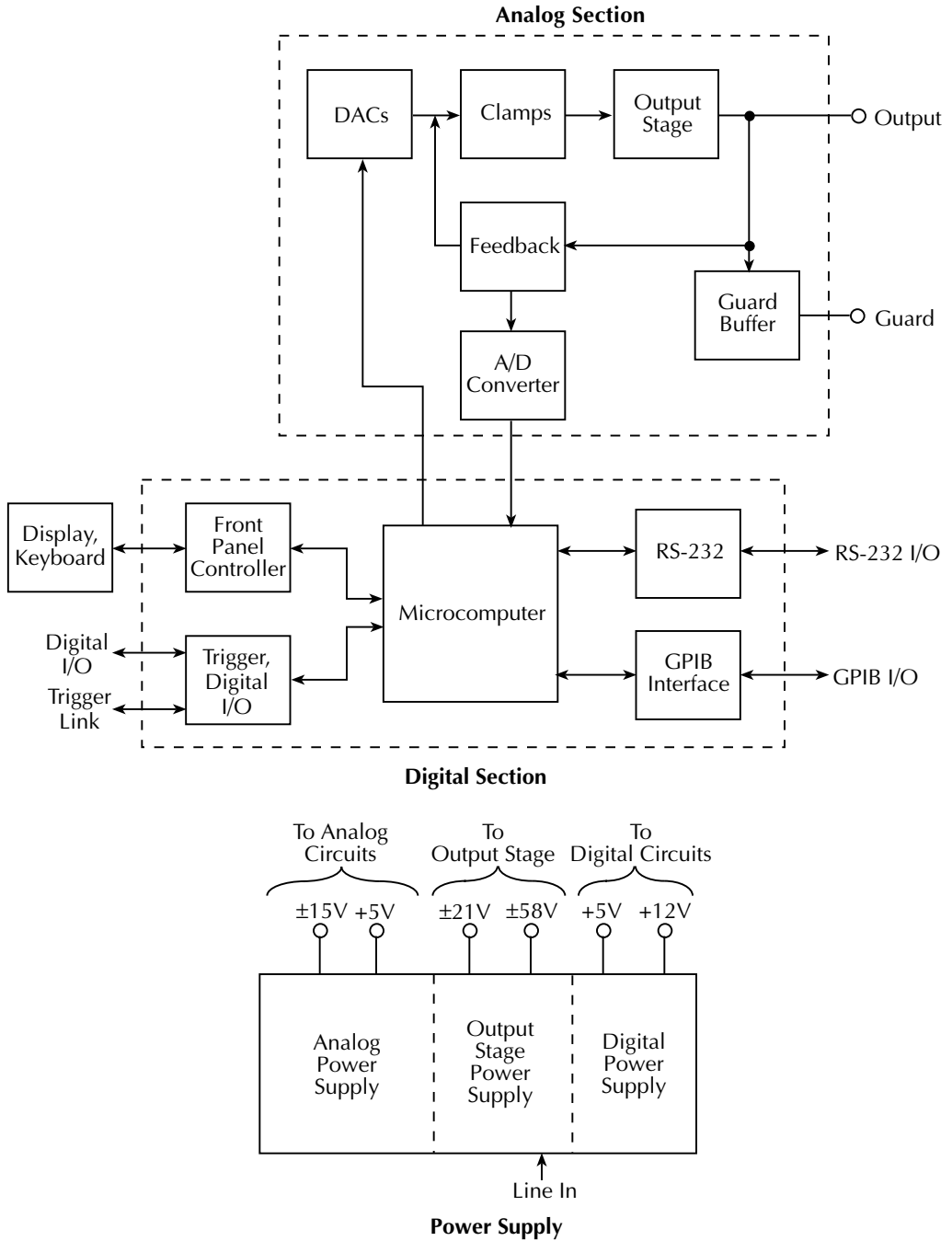
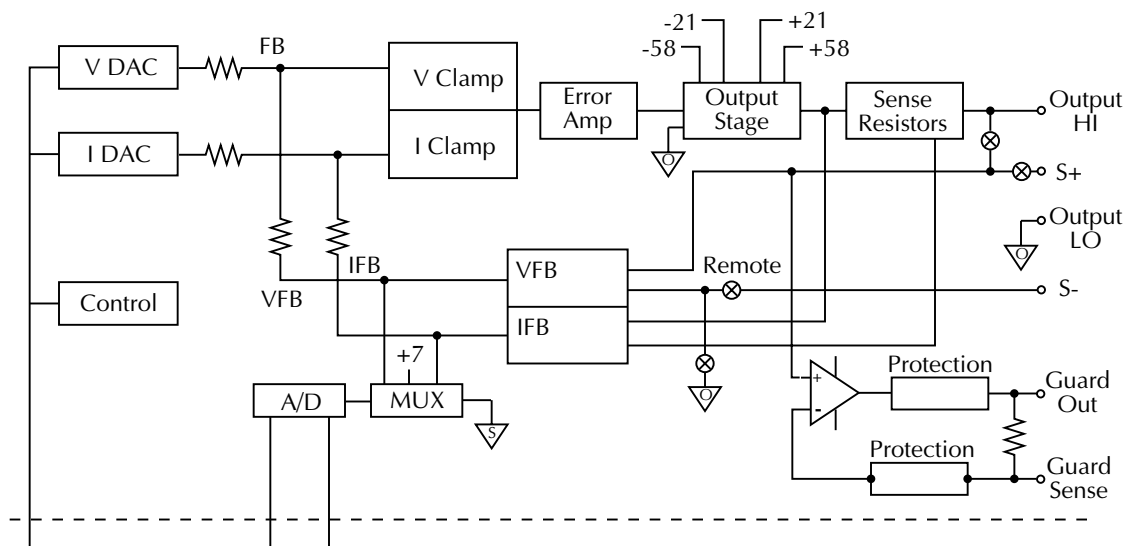

Figure 4-2
Analog circuitry block diagram



D/A converters control the programmed voltage and current, or voltage compliance and current compliance. Each DAC has two ranges, a 10V full-scale output or a 1V full-scale output. The DAC outputs are fed to the summing node, FB. Either the V DAC or the I DAC has the ability to control the main loop. If the unit is set for SV (source voltage), it will source voltage until the compliance current is reached (as determined by the I DAC setting), and the current loop will override the voltage loop. If, however, the unit is set for SI (source current), it will source current until the compliance voltage is reached (as determined by the V DAC setting), and the voltage loop will override the current loop. A priority bit in the V clamp/I clamp circuit controls these functions.

The error amplifier adds open-loop gain and slew-rate control to the system to assure accuracy and provide a controllable signal for the output stage, which provides the necessary voltage and current gain to drive the output. Sense resistors in the HI output lead provide output current sensing, and a separate sense resistor is used for each current range. The 1A and 5A ranges use 0.2V full-scale for a full-range output, while all other ranges use 2V output for full-scale current. Voltage feedback is routed either internally or externally.

There are four voltage ranges: 0.2V, 2V, 10V, and 40V. The feedback gain changes only for the 10V and 40V ranges, resulting in three unique feedback gain values. A multiplexer directs the voltage feedback, current feedback, reference, or ground signal to the A/D converter. An opto-isolated interface provides control signals for both DACs, analog circuit control, and A/D converter communication to the digital section.

Power supply

Figure 4-3 shows a block diagram of the Model 2440 power delivery system.

Figure 4-3

Power supply block diagram

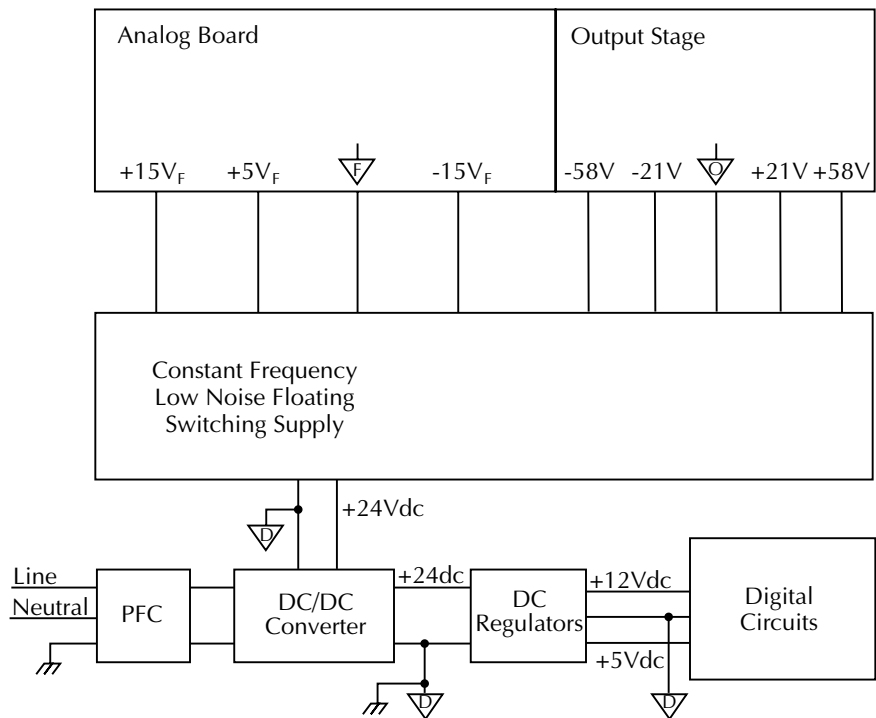

The offline switching power supply provides all power for the instrument while providing universal inputs and power factor correction for the 110/120V line. The digital board runs off of 5V and 12V supplies derived from the switcher. The +12VD supply is set to program the flash ROM. (See Digital circuitry below.)

A constant-frequency switching supply runs off the +24VD supplies and generates all the floating and output supply voltages for the analog board: +5V and $\pm 15V$, $\pm 21V$ and $\pm 58V$.

Output stage

Figure 4-4 shows a simplified schematic of the output stage.

Figure 4-4

Output stage simplified schematic

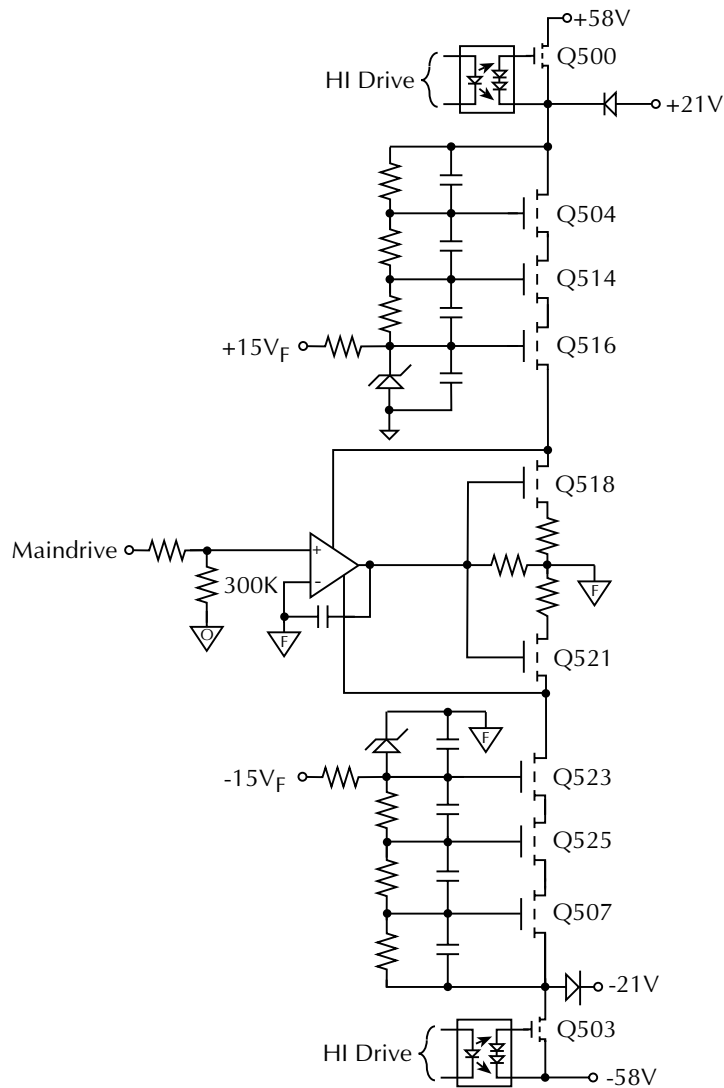

The Model 2440 output stage serves two purposes: (1) it converts signals from floating common to output common, and (2) it provides both voltage and current amplification. The output stage drive transistors are biased in class B configuration to prevent the possibility of thermal runaway with high-current output values.

Output transistors Q518 and Q521 are cascoded with output MOSFETs Q516 and Q523. All other MOSFETs and transistors are slaves, and the voltages across these devices are determined by the resistor-capacitor ladder circuits shown. High-current drive capability is provided by Q500-Q511. Coarse current limits are built into the output stage.

A/D converter

The SourceMeter unit uses a multi-slope charge balance A/D converter with a single-slope run-down. The converter is controlled by gate array U610. Commands are issued by the MPU on the digital board through communications opto-isolators to U610, and U610 sends A/D reading data back through opto-isolators to the digital board for calibration and processing.

Active guard

The Model 2440 has an active guard or “six-wire ohms” circuit used to measure complex devices. This circuitry provides a low-current (50mA) equivalent of the voltage on output HI. If the unit is in the SV mode, the low-current equivalent of the source voltage will appear on the guard terminal. If the unit is in the SI mode, the voltage on output HI is equal to the source current multiplied by the external resistance value. An equivalent voltage will be generated by the guard circuit, and a guard sense terminal is provided to sense around the voltage drop in the guard leads since significant current can flow (50mA).

Digital circuitry

Refer to [Figure 4-5](#) for the following discussion on digital circuitry.

The core digital circuitry uses a Motorola 68332 microcontroller running at 16.78MHz. The memory configuration includes two 256K X 8-bit flash EEPROMs and two 128K X 8-bit RAMs used in parallel to utilize the 16-bit data bus of the MPU. The RAM is battery backed-up, providing continued storage of data buffer information during power-down cycles, and flash ROM support allows internal firmware upgrades using either the serial or GPIB port for downloading new firmware. All calibration constants and the save 0 setup are stored in a separate serial EEPROM. Setups 1 through 4 are stored in battery backed-up RAM.

External communication is provided via GPIB and serial interfaces. A 9914 GPIB IEEE-488 standard interface IC is used for the GPIB, and a 68332 Queued Serial Module (QSM) provides the serial UART. For internal communications, the Time Processing Unit (TPU) is used for serial communications with the front panel display module, and both the TPU and QSM handle digital-to-analog interfacing.

Figure 4-5

Digital circuitry block diagram

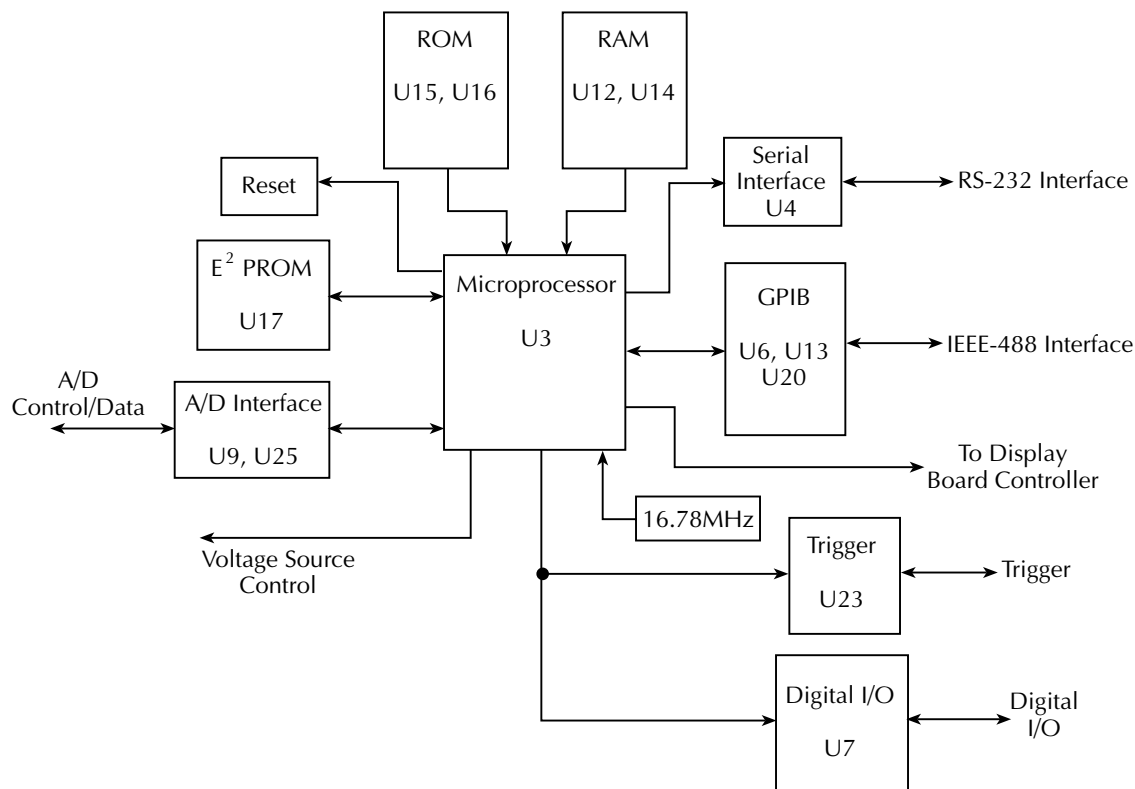

Display board circuit theory

U902 is the display microcontroller that controls the VFD (vacuum fluorescent display) and interprets key data. The microcontroller has four peripheral I/O ports that are used for the various control and read functions.

Display data is serially transmitted to the microcontroller from the digital board via the TXB line to the microcontroller PD0 terminal. In a similar manner, key data is serially sent back to the digital board through the RXB line via PD1. The 4MHz clock for the microcontroller is generated on the digital board.

DS901 is the VFD (vacuum fluorescent display) module, which can display up to 49 characters. Each character is organized as a 5×7 matrix of dots or pixels and includes a long under-bar segment to act as a cursor.

The display uses a common multiplexing scheme with each character refreshed in sequence. U903 and U904 are the grid drivers, and U901 and U905 are the dot drivers. Note that dot driver and grid driver data is serially transmitted from the microcontroller (PD3 and PC1).

The front panel keys (S901-S931) are organized into a row-column matrix to minimize the number of microcontroller peripheral lines required to read the keyboard. A key is read by strobing the columns and reading all rows for each strobed column. Key down data is interpreted by the display microcontroller and sent back to the main microprocessor using proprietary encoding schemes.

Troubleshooting

Troubleshooting information for the various circuits is summarized below.

Display board checks

If the front panel display tests indicate that there is a problem on the display board, use [Table 4-1](#). See “[Principles of operation](#)” for display circuit theory.

Table 4-1
Display board checks

Step	Item/component	Required condition	Remarks
1	Front panel test	Verify that all segments operate.	Use front panel display test.
2	J1033	+5V, $\pm 5\%$	Digital +5V supply.
3	U902, pin 1	Goes low briefly on power up, and then goes high.	Microcontroller RESET.
4	U902, pin 43	4MHz square wave.	Controller 4MHz clock.
5	U902, pin32	Pulse train every 1 ms.	Control from main processor.
6	U902, pine 33	Brief pulse train when front panel key is pressed.	Key down data sent to main processor.

Power supply checks

Power supply problems can be checked out using [Table 4-2](#). See “[Principles of operation](#)” for circuit theory on the power supply.

Table 4-2
Power supply checks

Step	Item/component	Required condition	Remarks
1	Line fuse	Check continuity.	Remove to check.
2	Line power	Plugged into live receptacle, power on.	Check for correct power-up sequence.
3	TP502	+58V, $\pm 10\%$	Referenced to TP501.
4	TP503	-58V, $\pm 10\%$	Referenced to TP501.
5	TP504	+21V, $\pm 10\%$	Referenced to TP501.
6	TP505	-21V, $\pm 10\%$	Referenced to TP501.
7	TP507	+15V, $\pm 5\%$	+15VF, referenced to TP500.
8	TP508	-15V, $\pm 5\%$	-15VF, referenced to TP500.
9	TP510	+5V, $\pm 5\%$	+5VF, referenced to TP500.

Digital circuitry checks

Digital circuit problems can be checked out using Table 4-3. See “Principles of operation” for a digital circuit description.

Table 4-3

Digital circuitry checks

Step	Item/component	Required condition	Remarks
1	Power-on test	RAM OK, ROM OK.	Verify that RAM and ROM are functional.
2	U3 pin 19	Digital common.	All signals referenced to digital common.
3	U3 pin 7	+5V	Digital logic supply.
4	U3 pin 68	Low on power-up, then goes high.	MPU RESET line.
5	U3, lines A0-A19	Check for stuck bits.	MPU address bus.
6	U3, lines D0-D15	Check for stuck bits.	MPU data bus.
7	U3 pin 66	16.78MHz.	MPU clock.
8	U4 pin 7	Pulse train during RS-232 I/O.	RS-232 RX line.
9	U4 pin 8	Pulse train during RS-232 I/O.	RS-232 TX line.
10	U13 pins 34-42	Pulse train during IEEE-488 I/O.	IEEE-488 data bus.
11	U13 pins 26-31	Pulses during IEEE-488 I/O.	IEEE-488 command lines.
12	U13 pin 24	Low with remote enabled.	IEEE-488 REN line.
13	U13 pin 25	Low during interface clear.	IEEE-488 IFC line.
14	U3 pin 43	Pulse train.	D_ADDDATA
15	U3 pin 44	Pulse train.	D_DATA
16	U3 pin 45	Pulse train.	D_CLK
17	U3 pin 47	Pulse train	D_STB

Analog circuitry checks

Table 4-4 summarizes analog circuitry checks.

Table 4-4

Analog circuitry checks

Step	Item/component	Required condition	Remarks
1	TP200*	>60V voltage protection	-13V \pm 1V
2	TP201*	SOURCE +10V	-5V \pm 0.5V
3	TP202*	SOURCE +10V (SVMI)	-10V \pm 1V
4	TP203*	SOURCE +10V	-10.5V \pm 1V
5	TP213*	SOURCE +10V	0V \pm 0.1V
6	TP218**	OUTPUT COM	7V \pm 0.7V
7	TP219**	OUTPUT COM	7V \pm 0.7V
8	TP214**	SVMI, OUTPUT ON, 20V	20V \pm 0.5V
9	TP232*	Bench defaults	6.4V \pm 0.6V

*Measured with respect to FCOM (TP500).

**Measured with respect to OCOM (TP501).

Battery replacement

WARNING Disconnect the instrument from the power line and all other equipment before changing the battery.

The volatile memories of the Model 2440 are protected by a replaceable battery when power is off. Typical battery life is approximately 10 years. The battery should be suspected if the instrument no longer retains buffer data or user-defined operating parameters such as instrument setups, source memory, and math expressions. If the battery is absent or totally exhausted, the display will show the “Reading buffer data lost” message shortly after the Model 2440 is switched on.

The battery is a 3V wafer-type lithium cell, Panasonic type BR-2330 or equivalent (Keithley part number BA-46), which is located on the digital board. Replacement of the battery requires removal of the case cover and analog board assembly. (See [Section 5](#).)

Battery replacement precautions

WARNING The precautions below must be followed to avoid personal injury.

1. Wear safety glasses or goggles when working with lithium batteries.
2. Do not short the battery terminals together.
3. Keep lithium batteries away from all liquids.
4. Do not attempt to recharge lithium batteries.
5. Observe proper polarity when installing the battery.
6. Do not incinerate or otherwise expose the battery to excessive heat ($>60^{\circ}\text{C}$).
7. Bulk quantities of lithium batteries should be disposed of as hazardous waste.

Battery replacement procedure

1. Remove the case cover and analog board assembly as covered in Section 5.
2. Locate the battery on the digital board.
3. Carefully unsolder and remove the old battery.
4. Install and solder the new battery in place.
5. Reassemble the instrument, and turn it on. The “Reading buffer data lost” error message will be displayed.
6. Send the `:SYST:MEM:INIT` command via remote to perform the following:
 - Clear the reading buffer.
 - Initialize instrument setups 1 through 4 to present instrument settings.
 - Initialize all 100 source memory locations to present instrument settings.
 - Delete user math expressions.

No comm link error

A “No Comm Link” error indicates that the front panel processor has stopped communicating with the main processor, which is located on the digital board. This error indicates that one of the main processor ROMs may require re-seating in its socket. ROMs may be reseated as follows:

1. Turn off the power, and disconnect the line cord and all other test leads and cables from the instrument.
2. Remove the case cover as outlined in [Section 5](#).
3. Remove the analog board assembly as outlined in [Section 5](#).
4. Locate the two firmware ROMs, U15 and U16, located on the digital board. These are the only ICs installed in sockets. (Refer to the component layout drawing at the end of [Section 6](#) for exact locations.)
5. Carefully push down on each ROM IC to make sure it is properly seated in its socket.

CAUTION Be careful not to push down excessively, or you might crack the digital board.

6. Connect the line cord, and turn on the power. If the problem persists, additional troubleshooting will be required.

5 Disassembly

Introduction

This section explains how to handle, clean, and disassemble the Model 2440. Disassembly drawings are located at the end of this section.

Handling and cleaning

To avoid contaminating PC board traces with body oil or other foreign matter, avoid touching the PC board traces while you are repairing the instrument. Motherboard areas covered by the shield have high-impedance devices or sensitive circuitry where contamination could cause degraded performance.

Handling PC boards

Observe the following precautions when handling PC boards:

- Wear cotton gloves.
- Only handle PC boards by the edges and shields.
- Do not touch any board traces or components not associated with repair.
- Do not touch areas adjacent to electrical contacts.
- Use dry nitrogen gas to clean dust off PC boards.

Solder repairs

Observe the following precautions when you must solder a circuit board:

- Use an OA-based (organic activated) flux, and take care not to spread the flux to other areas of the circuit board.
- Remove the flux from the work area when you have finished the repair by using pure water with clean, foam-tipped swabs or a clean, soft brush.
- Once you have removed the flux, swab only the repair area with methanol, then blow-dry the board with dry nitrogen gas.
- After cleaning, allow the board to dry in a 50°C, low-humidity environment for several hours.

Static sensitive devices

CMOS devices operate at very high impedance levels. Therefore, any static that builds up on you or your clothing may be sufficient to destroy these devices if they are not handled properly. Use the following precautions to avoid damaging them:

CAUTION Many CMOS devices are installed in the Model 2440. Handle all semiconductor devices as being static sensitive.

- Transport and handle ICs only in containers specially designed to prevent static build-up. Typically, you will receive these parts in anti-static containers made of plastic or foam. Keep these devices in their original containers until ready for installation.
- Remove the devices from their protective containers only at a properly grounded work station. Also, ground yourself with a suitable wrist strap.
- Handle the devices only by the body; do not touch the pins.
- Ground any printed circuit board into which a semiconductor device is to be inserted to the bench or table.
- Use only anti-static type desoldering tools.
- Use only grounded-tip solder irons.
- Once the device is installed in the PC board, it is normally adequately protected, and you can handle the boards normally.

Assembly drawings

Use the assembly drawings located at the end of this section to assist you as you disassemble and re-assemble the Model 2440. Also, refer to these drawings for information about the Keithley part numbers of most mechanical parts in the unit. Assembly drawings include:

- Front panel assembly — 2440-040
- Analog board/heat sink/shield assembly — 2440-050
- Chassis assembly — 2440-051
- Chassis/analog board assembly — 2440-052
- Final chassis assembly — 2440-053

Case cover removal

Follow the steps below to remove the case cover to gain access to internal parts.

WARNING Before removing the case cover, disconnect the line cord and any test leads from the instrument.

1. **Remove handle** — The handle serves as an adjustable tilt-bail. Adjust its position by gently pulling it away from the sides of the instrument case and swinging it up or down. To remove the handle, swing the handle below the bottom surface of the case and back until the orientation arrows on the handles line up with the orientation arrows on the mounting ears. With the arrows lined up, pull the ends of the handle away from the case.
2. **Remove mounting ears** — Remove the screw that secures each mounting ear. Pull down and out on each mounting ear.

NOTE When reinstalling the mounting ears, make sure to mount the right ear to the right side of the chassis, and the left ear to the left side of the chassis. Each ear is marked “RIGHT” or “LEFT” on its inside surface.

3. **Remove rear bezel** — To remove the rear bezel, loosen the two screws that secure the rear bezel to the chassis, then pull the bezel away from the case.
4. **Remove grounding screws** — Remove the two grounding screws that secure the case to the chassis. They are located on the bottom of the case at the back.
5. **Remove chassis** — To remove the case, grasp the front bezel of the instrument, and carefully slide the chassis forward. Slide the chassis out of the metal case.

NOTE To gain access to the components under the analog board shield, remove the shield, which is secured to the analog board by a single screw.

Analog board removal

Perform the following steps to remove the analog board. This procedure assumes that the case cover is already removed.

1. Disconnect the front and rear input terminals.

You must disconnect these input terminal connections for both the front and rear inputs:

- INPUT/OUTPUT HI and LO
- 4-WIRE SENSE HI and LO
- V, Ω , GUARD and GUARD SENSE (rear panel only)

Remove all the connections by pulling the wires off the pin connectors, then remove the ferrite noise filters from the chassis. During re-assembly, use the following table to identify input terminals:

Input terminals	Front wire color	Rear wire color
INPUT/OUTPUT HI	Red	White/Red
INPUT/OUTPUT LO	Black	White/Black
4-WIRE SENSE HI	Yellow	White/Yellow
4-WIRE SENSE LO	Gray	White/Gray
V, Ω , GUARD	-	White
GUARD SENSE	-	Blue/White

2. Unplug cables.
 - Carefully unplug the ribbon cables at J1027, J1028, and J1029.
 - Unplug the ON/OFF cable at J1034.
3. Remove screws.
 - Remove the two fastening screws that secure the analog board assembly to the chassis. These screws are located on the side of the board opposite from the heat sink.
 - Remove the two screws that secure the heat sink to the chassis.
4. Remove analog board assembly.

After all screws have been removed, carefully lift the analog board assembly free of the main chassis.
5. Disassemble analog board assembly.
 - Remove the screws that secure the analog board and heat sink to the analog board subchassis.
 - Carefully remove the heat sink by sliding the clips off the power transistors.

CAUTION Be careful not to damage the heat sink insulation layer.

- Remove the analog board from the subchassis.
- Remove the four screws that secure the bottom cover, then remove the cover from the bottom of the PC board.

NOTE When reinstalling the heat sink, make sure that all clips are properly installed and centered on each pair of output transistors.

Digital board removal

Perform the following steps to remove the digital board. This procedure assumes that the analog board assembly is already removed.

NOTE *In order to remove the digital board, the display board must first be removed.*

1. Remove the IEEE-488, Digital I/O, and RS-232 fasteners.
The IEEE-488, Digital I/O, and RS-232 connectors each have two nuts that secure the connectors to the rear panel. Remove these nuts.
2. Remove the POWER switch rod.
At the switch, place the edge of a flat-blade screw driver in the notch on the push-rod. Gently twist the screw driver while pulling the rod from the shaft.
3. Unplug cables:
 - Unplug the display board ribbon cable.
 - Unplug the cables going to the power supply.
 - Unplug the rear panel power module cable.
 - The fan may need to be removed.
4. Remove digital board.
Slide the digital board forward until it is free of the guide pins, then remove the board.
During reassembly, replace the board, and start the IEEE-488, Digital I/O, and RS-232 connector nuts and the mounting screw. Tighten all the fasteners once they are all in place and the board is correctly aligned.

Front panel disassembly

Use the following procedures to remove the display board and/or the pushbutton switch pad.

1. Unplug the display board ribbon cables.
2. Remove the front panel assembly.
This assembly has four retaining clips that snap onto the chassis over four pem nut studs. Two retaining clips are located on each side of the front panel. Pull the retaining clips outward and, at the same time, pull the front panel assembly forward until it separates from the chassis.
3. Using a thin-bladed screw driver, pry the plastic PC board stop (located at the bottom of the display board) until the bar separates from the casing. Pull the display board from the front panel.
4. Remove the switch pad by pulling it from the front panel.

Removing power components

The following procedures to remove the power supply and/or power module require that the case cover and motherboard be removed, as previously explained.

Power module removal

Perform the following steps to remove the rear panel power module:

1. Remove the analog board.
2. Unplug the cable connecting the power module to the digital board.
3. Disconnect the power module's ground wire. This green and yellow wire connects to a threaded stud on the chassis with a kep nut.
4. Squeeze the latches on either side of the power module while pushing the module from the access hole.

WARNING To avoid electrical shock, which could result in injury or death, the ground wire of the power module must be connected to chassis ground. When installing the power module, be sure to reconnect the green and yellow ground wire to the threaded stud on the chassis.

Instrument reassembly

Reassemble the instrument by reversing the previous disassembly procedures. Make sure that all parts are properly seated and secured, and that all connections are properly made. To ensure proper operation, replace the analog signal wire ferrite noise filters, and securely fasten the shield.

WARNING To ensure continued protection against electrical shock, verify that power line ground (green and yellow wire attached to the power module) is connected to the chassis.

Also make sure the two bottom case screws are properly installed to secure and ground the case cover to the chassis.

6 Replaceable Parts

Introduction

This section contains replacement parts information and component layout drawings for the Model 2440.

Parts lists

The electrical parts lists for the Model 2440 are shown tables at the end of this section. For part numbers to the various mechanical parts and assemblies, use the Miscellaneous parts list and the assembly drawings provided at the end of [Section 5](#).

Ordering information

To place an order, or to obtain information concerning replacement parts, contact your Keithley representative or the factory (see inside front cover for addresses). When ordering parts, be sure to include the following information:

- Instrument model number (Model 2440)
- Instrument serial number
- Part description
- Component designation (if applicable)
- Keithley part number

Factory service

If the instrument is to be returned to Keithley Instruments for repair, perform the following:

- Call the Repair Department at 1-800-552-1115 for a Return Material Authorization (RMA) number.
- Complete the service form at the back of this manual, and include it with the instrument.
- Carefully pack the instrument in the original packing carton.
- Write ATTENTION REPAIR DEPARTMENT and the RMA number on the shipping label.

Component layouts

The component layouts for the various circuit boards are provided on the following pages. Drawings include:

- Analog board — 2440-120
- Display board — 2400-110
- Digital board — 2440-140

Table 6-1
Analog board parts list

Circuit Designation	Description	Keithley Part No.
C200-C203, C205-C210, C225, C226, C231, C232	CAP, .1UF, 10%, 25V, CERAMIC	C-495-.1
C204, C411, C608, C609	CAP, .01UF, 10%, 50V, CERAMIC	C-491-.01
C211, C212, C213, C214, C301, C302	CAP, 1000PF, 10%, 50V, MONO CERAMIC	C-452-1000P
C215-C222, C611, C331, C332, C333, C334	CAP, 100PF, 5%, 100V, CERAMIC	C-465-100P
C223, C224, C227, C229, C234-C236, C239, C240	CAP, 33PF, 5%, 100V, CERAMIC	C-465-33P
C230, C233	CAP, 7.5P, 10%, 100V, CERAMIC	C-452-7.5P
C237, C238, C242, C243, C248, C249, C254, C255	CAP, .1UF, 10%, 25V, CERAMIC	C-495-.1
C241	CAP, 1000PF, 1%, 50V, CERAMIC	C-347-1000P
C246, C336	CAP, 3300PF, 10%, 100V, CERAMIC	C-430-3300P
C247	CAP, .01, 5%, 50V, NPO	C-514-.01
C250, C251, C272, C297, C298, C299, C300, C524	CAP, .1UF, 10%, 25V, CERAMIC	C-495-.1
C258, C259, C260-C263, C269-C271, C273-C282	CAP, .1UF, 10%, 25V, CERAMIC	C-495-.1
C267, C268	CAP, 1000P, 10%, 100V, CERAMIC	C-451-1000P
C283	CAP, 100P, 10%, 100V, CERAMIC	C-451-100P
C284-C291, C305-C310, C321, C322, C548, C558	CAP, .1UF, 10%, 25V, CERAMIC	C-495-.1
C296, C330, C400	CAP, 270PF, 2.5%, 630V, POLYPROPYLENE	C-405-270P
C311	CAP, 100UF, 20%, 16V, TANTALUM	C-504-100
C312-C319	CAP, 10PF, 5%, 100V, CERAMIC	C-372-10P
C320	CAP, 33PF, 5%, 100V, CERAMIC	C-465-33P
C323, C324, C325, C326, C603, C604, C615	CAP, 47P, 5%, 100V, CERAMIC	C-465-47P
C327	CAP, 390P, 10%, 100V, CERAMIC	C-451-390P

Table 6-1 (continued)
Analog board parts list

Circuit Designation	Description	Keithley Part No.
C328	CAP, 22P, 2%, 200V, CERAMIC	C-531-22P
C329	CAP, 220PF, 10%, 100V, CERAMIC	C-451-220P
C409, C410	CAP, .15UF, 20%, 50V, CERAMIC	C-418-.15
C412	CAP, 1UF, 20%, 35V, TANTALUM	C-494-1
C501, C503	CAP, 3.3, 20%, 250V, ALUM ELECTROLYTIC	C-400-3.3
C502, C504, C505, C506, C550, C551, C552, C553	CAP, .01U, 10%, 500V, CERAMIC	C-497-.01
C512, C514, C256, C257	CAP, 22PF, 10%, 100V, CERAMIC	C-451-22P
C513	CAP, 560PF, 2.5%, 630V, POLYPROPYLENE	C-405-560P
C515, C541	CAP, .1UF, 20%, 50V, CERAMIC	C-418-.1
C522, C523, C526, C527	CAP, 3300P, 10%, 500V, CERAMIC	C-497-3300P
C525, C542, C549, C561, C564, C585	CAP, .1UF, 10%, 25V, CERAMIC	C-495-.1
C528, C533, C567, C568, C569, C570, C663, C664	CAP, 3300P, 10%, 500V, CERAMIC	C-497-3300P
C534, C535	CAP, 47U, 20%, 50V, ALUM	C-579-47
C543	CAP, 10PF, 10%, 1000V, CERAMIC	C-64-10P
C544, C545, C546, C547	CAP, .01U, 10%, 500V, CERAMIC	C-497-.01
C556, C557, C559, C560, C562, C563, C616	CAP, 22UF, 20%, 25V, TANTALUM	C-440-22
C565, C566, C581, C582, C600, C601, C602, C605	CAP, .1UF, 10%, 25V, CERAMIC	C-495-.1
C583, C584	CAP, 1000PF, 20%, 50V, CERAMIC	C-418-1000P
C606, C607, C613, C614, C617, C618, C619, C620	CAP, .1UF, 10%, 25V, CERAMIC	C-495-.1
C610, C612	CAP, 2200P, 10%, 100V, CERAMIC	C-430-2200P
C621, C622, C623, C624, C625, C650, C651, C652	CAP, .1UF, 10%, 25V, CERAMIC	C-495-.1
C659-C662	CAP, .1UF, 10%, 25V, CERAMIC	C-495-.1
CR200-CR205, CR207, CR208, CR210-CR213	DIODE, SWITCHING, MMBD914	RF-83
CR206, CR209, CR222, CR223, CR230-CR233	DIODE, 1N3595	RF-43
CR216-CR221, CR235, CR236, CR239, CR518	DIODE, SWITCHING, MMBD914	RF-83
CR224, CR225	SCHOTTKY BARRIER RECTIFIER	RF-154
CR237, CR523	DIODE, DUAL SWITCHING, BAV99L	RF-82
CR400, CR401	DIODE, 1N3595	RF-43
CR517, 519	SWITH MODE POWER RECTIFIER	RF-155

Table 6-1 (continued)
Analog board parts list

Circuit Designation	Description	Keithley Part No.
CR522, CR524, CR525	DIODE, SWITCHING, MMBD914	RF-83
CR600	DIODE, DUAL HSM-2822T31	RF-95
CR601	DIODE, SCHOTTKY, SD103C	RF-113
CR602	SCHOTTKY DIODE	RF-125
HS1, HS2, HS3, HS4, HS5, HS6, HS7, HS17, HS19	HEAT SINK	HS-55
J1027, J1036	CONN, HEADER STRAIGHT SOLDER PIN	CS-368-16
J1028	CONNECTOR, HEADER STRAIGHT SOLDER PIN	CS-368-14
J1029	CONN, MALE, 5-PIN (MOLEX 42491)	CS-784-5
J1034, J1037, J1038	LATCHING HEADER, FRICTON, SGL ROW	CS-724-3
K200-K205	N.C RELAY, 1 FORMB, AQV214S	RL-176
K206, K207, K208	FORM 2A2B POLARIZED RELAY, S28B-5V	RL-207
K211, K500	RELAY, SURFACE MOUNT	RL-188
K215	NON LATCHING RELAY	RL-242
L201, L500, L501	CHOKE, SHIELD BEAD	CH-52
L600, L601, L602	FERRITE CHIP, 600 OHM, BLM32A07	CH-62
L603	FERRITE CHIP, 600 OHM, BLM32A07	CH-62
Q200, Q201, Q202, Q203, Q204, Q205, Q206, Q207	TRANS, N CHANNEL JFET, SNJ132199	TG-294
Q208, Q210, Q212, Q214, Q216, Q218	TRANS, NPN CATV SILICON, MPSH17	TG-221
Q209, Q211, Q213, Q215, Q217, Q219	TRANS, CURR REG, CDLL5313	TG-321
Q220	TRANS, NPN SILICON, MJE340	TG-209
Q221	TRANS, PNP POWER, MJE350	TG-210
Q222, Q224	TRANS, N-CHAN JFET, SST4393	TG-263
Q223, Q229, Q234-Q239, Q244, Q245, Q246, Q255	TRANS, N-MOSFET, VN0605T	TG-243
Q225	TRANS, NPN SILICON, MJD340	TG-373
Q226	TRANS, PNP SILICON, MJD350	TG-374
Q227, Q257, Q501, Q510, Q515, Q517, Q519, Q522	TRANS, NPN, MMBT3904	TG-238
Q228, Q247, Q248, Q520, Q601	TRANS, PNP, MMBT3906L	TG-244
Q240, Q241	TRANS, N CHANNEL JFET, SNJ132199	TG-294
Q242, Q243	TRANS, N-CHAN MOSFET, TN254ON8	TG-274
Q249, Q528	TRANS, NPN SILICON, BC846BL,	TG-278
Q250, Q529	TRANS, PNP, BC856BL	TG-287

Table 6-1 (continued)
Analog board parts list

Circuit Designation	Description	Keithley Part No.
Q256, Q258, Q401, Q404, Q405, Q410, Q411, Q420	TRANS, N-MOSFET, VN0605T	TG-243
Q402, Q409, Q259	TRANS, N-CHAN DMOS, FET TN2504N8	TG-261
Q403, Q406, Q407, Q408	TRANS, N-CHAN JFET, SST109	TG-266
Q412, Q414	TRANS, N-MEGAFET, RFD14N05LSM	TG-267
Q415, Q416	TRANS, HEXFET POWER MOSFET, IRFR5305	TG-377
Q417, Q419	TRANS, N-CHANNEL MOSFET, RFD16N05LSM	TG-339
Q418, Q542, Q230	TRANS, P-CHAN, MOSFET, TP0610T	TG-259
Q500, Q503	TRANS, POWER MOSFET, IRF3415S	TG-372
Q502, Q540, Q541, Q602-Q605	TRANS, N-MOSFET, VN0605T	TG-243
Q504, Q514, Q516, Q518	N-CHANNEL POWER MOSFET	TG-349
Q507, Q521, Q523, Q525	P-CHANNEL POWER MOSFET	TG-348
Q524, Q534, Q535, Q537, Q538, Q600	TRANS, NPN, MMBT3904	TG-238
Q526, Q527, Q530, Q531	TRANS, N-CHANNEL, MOSFET, SI9410DY	TG-302
Q532, Q536	TRANS, N-CHANNEL, FET, IRF630	TG-214
Q533, Q539	TRANS, P-CHANNEL, 200V FET, IRF9630	TG-215
R117-R128, R133-R136, R141-R144	RES, 10K, 5%, 250MW, METAL FILM	R-376-10K
R129, R155, R211, R224-R229, R234-R237	RES, 10K, 1%, 100MW, THICK FILM	R-418-10K
R130	RES, 10K, 1%, 100MW, THICK FILM	R-418-10K
R137-140, R145-149, R713, R714	RES, 10K, 5%, 250MW, METAL FILM	R-376-10K
R150, R151, R389, R390, R451, R520, R531, R559	RES, 1K, 1%, 100MW, THICK FILM	R-418-1K
R152, R656	RES, 4.99K, .1%, .125W, THIN FILM	R-456-4.99K
R153, R154, R240, R243, R248, R251, R253, R254	RES, 4.99K, 1%, 100MW, THICK FILM	R-418-4.99K
R200, R201, R203, R232, R238	RESISTOR NETWORK, 10K-10K	TF-236
R202, R204, R252, R255, R256, R259, R260, R263	RES, 100K, 1%, 100MW, THICK FILM	R-418-100K
R205, R310, R485, R552, R595, R598, R723, R724	RES, .0499, 1%, 100MW, THICK FILM	R-418-.0499
R207	RES, 20K, .1%, .125W, THIN FILM	R-456-20K
R208, R210	RES, 768, 1%, 100MW, THICK FILM	R-418-768
R209, R268, R269, R270, R271, R672	RES, 1M, 1%, 100MW, THICK FILM	R-418-1M
R213	RES NET, 5K, .1%, 668A	TF-243-5K

Table 6-1 (continued)
Analog board parts list

Circuit Designation	Description	Keithley Part No.
R216, R221, R223, R274, R275, R276, R277, R278	RES, 20K, 1%, 100MW, THICK FILM	R-418-20K
R217	RES, 121K, 1%, 100MW, THICK FILM	R-418-121K
R218	RES, 80.6K, 1%, 100MW, THICK FILM	R-418-80.6K
R219, R220, R222, R230, R231, R373, R374, R616	RES, 49.9K, 1%, 100MW, THICK FILM	R-418-49.9K
R241, R242, R249, R250, R653, R664	RES, 140K, 1%, 100MW, THICK FILM	R-418-140K
R244-R247, R281, R282, R284-R286, R288, R301	RES, 10K, 1%, 100MW, THICK FILM	R-418-10K
R257, R258, R261, R262, R265, R266, R311, R312	RES, 4.99K, 1%, 100MW, THICK FILM	R-418-4.99K
R264, R267, R364, R370, R371, R372, R402	RES, 100K, 1%, 100MW, THICK FILM	R-418-100K
R272, R273, R347, R348, R511, R512, R589	RES, 249K, 1%, 100MW, THICK FILM	R-418-249K
R279	RES, 20K, 1%, 100MW, THICK FILM	R-418-20K
R280, R516, R523	RES, 4.02K, 1%, 100MW, THICK FILM	R-418-4.02K
R283, R287, R297, R299, R349, R350, R351, R352	RES, 30.1K, 1%, 100MW, THICK FILM	R-418-30.1K
R289, R303, R681, R684	RES, 20K, .1%, .125W, THIN FILM	R-456-20K
R290, R309, R336, R340, R343, R344, R353, R355	RES, 1K, 1%, 100MW, THICK FILM	R-418-1K
R291, R293, R682, R685	RES, 42.7K, .1%, .125W, THIN FILM	R-456-42.7K
R292, R338, R527, R528, R533, R535, R544, R546	RES, 100K, 1%, 100MW, THICK FILM	R-418-100K
R294, R295, R296	RES, 100K, .1%, .125W, THIN FILM	R-456-100K
R298, R300	RES, 150K, 1%, 100MW, THICK FILM	R-418-150K
R302	RES, .0499, 1%, 100MW, THICK FILM	R-418-.0499
R304, R305, R306, R548	RES, 33, 5%, 250MW, METAL FILM	R-376-33
R307, R413, R652, R665	RES, 357, 1%, 100MW, THICK FILM	R-418-357
R308, R379-R387, R391, R392	RES, 475, 1%, 100MW, THICK FILM	R-418-475
R313, R314, R315, R316, R317, R334, R335, R337	RES, 4.99K, 1%, 100MW, THICK FILM	R-418-4.99K
R318, R563, R358	RES, 15K, 1%, 100MW, THICK FILM	R-418-15K
R332, R423, R430, R604, R606, R436	RES, 499, 1%, 100MW, THICK FILM	R-418-499
R339, R357, R366, R367, R424, R425, R426, R429	RES, 4.99K, 1%, 100MW, THICK FILM	R-418-4.99K

Table 6-1 (continued)
Analog board parts list

Circuit Designation	Description	Keithley Part No.
R341, R342, R505	RES, 13K, 1%, 100MW, THICK FILM	R-418-13K
R345	RES, 316K, 1%, 100MW, THICK FILM	R-418-316K
R346	RES, 392K, 1%, 100MW, THICK FILM	R-418-392K
R354, R437	RES, 560K, 5%, 250MW, METAL FILM	R-376-560K
R356, R359, R361, R362, R365, R369, R418, R419	RES, 1K, 1%, 100MW, THICK FILM	R-418-1K
R363	RES NET, VARIOUS, .1%, .1W	TF-283
R368, R212	RES, 332, 1%, 100MW, THICK FILM	R-418-332
R375, R376, R576, R578, R536, R537	RES, 10, 10%, 100MW, THICK FILM	R-418-10
R388, R393-R399, R411, R412, R699	RES, 357, 1%, 100MW, THICK FILM	R-418-357
R403, R404, R416, R417, R459, R488, R560	RES, 100K, 1%, 100MW, THICK FILM	R-418-100K
R420, R421, R456, R458, R460, R462, R466, R472	RES, 1K, 1%, 100MW, THICK FILM	R-418-1K
R422	RES, 4.7K, 5%, 250MW, METAL FILM	R-376-4.7K
R431, 432	RES, 3.01K, 1%, 100MW, THICK FILM	R-418-3.01K
R433, R434	RES, 1K, 1%, 100MW, THICK FILM	R-418-1K
R435, R504, R590, R673, R688, R689, R716, R715,	RES, 10K, 1%, 100MW, THICK FILM	R-418-10K
R438, R439, R592, R617, R622, R654, R655, R687	RES, 10K, 1%, 100MW, THICK FILM	R-418-10K
R450	RES, 200K, .1%, 1/10W, METAL FILM	R-263-200K
R452	RES, 21.93K, .1%, 1/10W, METAL FILM	R-263-21.93K
R453	RES, 1.82K, .1%, 1/10W, METAL FILM	R-263-1.82K
R454, R455, R467, R468, R469, R470, R471	RES, 100, .1%, 1/10W, METAL FILM	R-263-100
R457, R461, R463, R473, R479, R697, R698	RES, 30.1K, 1%, 100MW, THICK FILM	R-418-30.1K
R475	RES, 1, 1%, 1/5W, WIRE	R-501-1
R478, R481, R489, R502, R510, R558, R675, R704	RES, 1K, 1%, 100MW, THICK FILM	R-418-1K
R482, R484, R487	RES, 6.04K, 1%, 100MW, THICK FILM	R-418-6.04K
R483, R691, R695, R721	RES, 2K, 1%, 100MW, THICK FILM	R-418-2K
R490	RES, 205, .1%, 1/10W, METAL FILM	R-263-205
R503, R545, R587	RES, 15K, 1%, 100MW, THICK FILM	R-418-15K
R508, R509, R506, R507	RES, 150K, 5%, 250MW, METAL FILM	R-376-150K

Table 6-1 (continued)
Analog board parts list

Circuit Designation	Description	Keithley Part No.
R517, R524, R564, R565, R566, R567	RES, 12.1, 1%, 1/4W, METAL FILM	R-391-12.1
R521, R658	RES, 2M, 1%, 100MW, THICK FILM	R-418-2M
R525, R526	RES, 1.21K, 1%, 100MW, THICK FILM	R-418-1.21K
R530, R532, R534, R712	RES, 1K, 1%, 100MW, THICK FILM	R-418-1K
R538, R540, R568, R569	RES, .5, 5%, 1W, METAL FILM	R-444-.5
R539, R541, R542, R543	RES, .25, 1%, IN, METAL	R-444-.25
R547, R588	RES, 100K, 1%, 100MW, THICK FILM	R-418-100K
R553, R554	RES, 75K, 1%, 100MW, THICK FILM	R-418-75K
R561, R562, R600, R500, R515, R722	RES, 100K, 1%, 100MW, THICK FILM	R-418-100K
R570, R571, R573, R581, R705	RES, 249, 1%, 100MW, THICK FILM	R-418-249
R572, R574, R580, R582	RES, 200K, 1%, 100MW, THICK FILM	R-418-200K
R575, R579, R614, R615	RES, 2.21K, 1%, 100MW, THICK FILM	R-418-2.21K
R586	RES, 10, 5%, 125MW, METAL FILM	R-375-10
R601, R603, R605, R608, R626, R702, R703	RES, 4.99K, 1%, 100MW, THICK FILM	R-418-4.99K
R602, R607	RES, 150, 5%, 250MW, METAL FILM	R-376-150
R609	RES NET	TF-245
R610	RES, 1.28M, .1%, 1/8W, METAL FILM	R-176-1.28M
R611, R621	RES, 475, 1%, 100MW, THICK FILM	R-418-475
R612	RES, 5.11K, 1%, 100MW, THICK FILM	R-418-5.11K
R613, R624, R659, R660	RES, 100, 1%, 100MW, THICK FILM	R-418-100
R618	RES, 34K, 1%, 100MW, THICK FILM	R-418-34K
R619	RES, 4.75K, 1%, 100MW, THICK FILM	R-418-4.75K
R620	RES, 82.5, 1%, 100MW, THICK FILM	R-418-82.5
R623	RES, 10, 10%, 100MW, THICK FILM	R-418-10
R650	RES NET, 9K-1K, MICRO DIVIDER	TF-246-2
R651	RES NET, 20K, .1%, .2W, MICRO DIVIDE	TF-250
R657, R692, R696	RES, 1M, 1%, 100MW, THICK FILM	R-418-1M
R666	RES NET, 3K, 12K, 0.1%, 100MW, THIN FILM	TF-237-2
R670	RES, 1K, 1%, 100MW, THIN FILM	R-438-1K
R671	RES, .0499, 1%, 100MW, THICK FILM	R-418-.0499
R680	RES, 8.87K, 1%, .1W, THIN FILM	R-438-8.87K
R683, R686	RES, 1K, .1%, .125W, THIN FILM	R-456-1K
R690, R694	RES, 100K, 5%, 250MW, METAL FILM	R-376-100K
R700, R701	RES, 49.9K, 1%, 100MW, THICK FILM	R-418-49.9K
R706, R707, R708, R709, R501, R514, R529,	RES, 1K, 1%, 100MW, THICK FILM	R-418-1K

Table 6-1 (continued)
Analog board parts list

Circuit Designation	Description	Keithley Part No.
R710	RES, .039, 1%, 3W, KELVIN	R-474-.039
R717, R718	RES, 10, 5%, 250MW, METAL FILM	R-376-10
R719	RES, 100, 5%, 125MW, METAL FILM	R-375-100
R730	RES, 174K, 1%, 100MW, THIN FILM	R-438-174K
R731	RES, 38.3K, 1%, 100MW, THIN FILM	R-438-38.3K
RT200	POLYSWITCH, PTC RESISTOR	RT-17
RT500	THERMISTER, PD=7MW/DEG C, 1500V, 613.74K	RT-8
TP200-TP215, TP218-TP225, TP227, TP228	SURFACE MOUNT PCB TEST POINT	CS-1026
TP230-TP235, TP500-TP505, TP507, TP508	SURFACE MOUNT PCB TEST POINT	CS-1026
TP510	SURFACE MOUNT PCB TEST POINT	CS-1026
U201, U238	IC, CMOS ANA SWITCH SPST, MAX326CSE	IC-909
U202, U203, U650	IC, OP AMP, LT1112	IC-1048
U204, U229	IC, 8-CHAN ANA MULTIPLEXER, DG408DY	IC-844
U205, U407	IC, HEX INVERTERS, 74HCT04	IC-880
U206, U207, U208, U233, U264, U600	IC, DUAL PICOAMP OP-AMP, AD706JR	IC-910
U209, U215	IC, QUAD COMPARATOR, LM339D	IC-774
U210, U220	IC, DUAL BIPOLAR OP-AMP, LT1124CS8	IC-955
U211, U213	IC, BIFET OP AMP, AD712JR	IC-834
U212, U214, U230, U241, U400- U406, U652	IC, CMOS ANAL SWITCH, DG444DY	IC-866
U216, U218, U225, U410	IC, DUAL J-FET OP-AMP, OP-282GS	IC-968
U219, U231, U234, U235, U262	IC, OP AMP, LOW POWER, AD795JR	IC-1052
U221, U227	IC, DIFF. AMP, AMP03GP	IC-988
U222	IC, OP-AMP, LTC1050CS8	IC-791
U223, U411, U507, U508	IC, MOSFET DRIVER, TLP591B	IC-877
U224, U602, U603, U651, U510, U662	IC, QUAD 2 IN NOR, 74HCT02	IC-809
U226, U659	IC, 20V OP-AMP, LT1097S8	IC-767
U228, U263	IC, OP-AMP, LOW NOISE, LT1007CS8	IC-949
U236, U606	IC, HI-SPEED BIFET OP-AMP, AD711JR	IC-894
U239, U266	IC, QUAD 2-INPUT NAND, 74HC00M	IC-781
U240	IC, POS NAND GATES/INVERT, 74HCT14	IC-656
U242, U243, U244, U245, U246, U247	IC, DUAL HIGH CMR/SPEED OPTO, HCPL-2631	IC-588
U252, U253, U254, U255, U256	IC, 8 STAGE SHIFT, C074HC409AM	IC-1026

Table 6-1 (continued)
Analog board parts list

Circuit Designation	Description	Keithley Part No.
U257	IC, SUPPLY VOLT SUPERVISOR, TL7705A	IC-860
U265	IC, QUAD 2-INPUT NAND GATE	IC-1148
U500	IC, OP-AMP, AD847JN	IC-890
U501, U506, U513, U514	IC, VOLT COMPARATOR, LM393D	IC-775
U503	IC, +5V VOLTAGE REGULATOR, LM2940CT	IC-576
U504	IC, POS VOLTAGE REG, +15V, 500MA, 78M15	IC-194
U505	IC, NEG VOLTAGE REG, -15V, 500MA, 79M15	IC-195
U511, U512	IC, PROGRAMMABLE TEMP CONTROLLER	IC-1062
U515	IC, HIGH SPEED OPTOCOUPLER	IC-1173
U601	IC, QUAD D FLIP FLOP W/CLK, RESET, 74HC175	IC-923
U604	IC, NCHAN LAT DMOS QUADFET, SD5400CY	IC-893
U605	IC, OPA177GS	IC-960
U607	IC, OP-AMP, NE5534D	IC-802
U608	IC, VOLT. COMPARATOR, LM311M	IC-776
U609	PROGRAMMED ROM	2400-801*
U660, U661	IC, 16 BIT DAC, AD7849BR	IC-1004
VR200, VR201	DIODE, ZENER, MM524694 TI	DZ-113
VR202, VR203, VR407, VR408, VR409, VR506	DIODE, ZENER, 5.1V, BZX84C5V1	DZ-88
VR214, VR215	DIODE, ZENER, 8.2V, MMBZ5237	DZ-92
VR400, VR401	DIODE, ZENER, 4.7V, 1N4732A	DZ-67
VR410, VR514, VR515, VR601, VR604	DIODE, ZENER, 3.3V, MMBZ5226BL	DZ-94
VR500, VR501	DIODE, ZENER, 12V, MMSZ12T1	DZ-112
VR502, VR503	DIODE, ZENER, 11V, MMSZ11T1	DZ-103
VR507	DIODE, ZENER, 5.1V, BZX84C5V1	DZ-88
VR509, VR510	DIODE, ZENER, 15V, 1N4744A	DZ-75
VR600	DIODE, DT-2776	DZ-127
VR602, VR603	DIODE, ZENER, 6.2V, MMSZ6V2	DZ-97
VR605, VR606	DIODE, ZENER, 17V, MMBZ5247BL	DZ-104
Y600	OSCILLATOR HIGH SPEED CMOS, 12MHZ	CR-37

*Order current firmware revision, for example: 2400-801A01.

Table 6-2
Digital board parts list

Circuit Designation	Description	Keithley Part No.
BT1	3V BATTERY	BA-46
C1, C3, C77, C11-C14, C16, C17, C20, C22, C23	CAP, .1UF, 10%, 25V, CERAMIC	C-495-.1
C103	CAP, 100UF, 20%, 10V, ALUM ELEC	C-483-100
C104	CAP, 10UF, 20%, 63V, ALUM ELEC	C-403-10
C105, C108	CAP, 220U, 20%, 50V, ALUM ELEC	C-619-220
C107, C110	CAP, 82U, 20%, 450V, ALUMINUM	C-554-82
C109, C111	CAP, 220U, 20%, 50V, ALUM ELEC	C-579-220
C113, C115, C117, C119	CAP, 10U, 20%, 35V, TANTALUM	C-551-10
C114	CAP, 220UF, +/-20%, 50V, ALUM ELEC	C-507-220
C116	CAP, 100UF, 20%, 16V, ALUM ELEC	C-530-100
C120	CAP, 270PF, 5%, 100V, CERAMIC	C-465-270P
C122, C125	CAP, .47U, 20%, 25V	C-520-.47
C123	CAP, .1UF, 20%, 50V, CERAMIC	C-418-.1
C126	CAP, 100P, 10%, 100V, CERAMIC	C-451-100P
C127, C128, C129, C130, C211	CAP, 100P, 10%, 100V, CERAMIC	C-451-100P
C131	CAP, 470U, 20%, 50V, ALUM ELEC	C-570-470
C15, C37, C204, C205, C206, C207, C208, C209	CAP, .01U, 10%, 500V, CERAMIC	C-497-.01
C19, C69, C85, C75, C92, C200, C201, C510, C511	CAP, .1UF, 10%, 25V, CERAMIC	C-495-.1
C2, C56, C76, C78, C8, C80, C82, C87, C88, C89	CAP, .01UF, 10%, 50V, CERAMIC	C-491-.01
C202	CAP, 47PF, 10%, 100V, CERAMIC	C-451-47P
C203	CAP, 1000PF, 10%, 50V, MONO CERAMIC	C-452-1000P
C24, C96	CAP, .1U, 20%, 250V, FILM	C-553-.1
C25, C26, C30, C39, C41, C42, C49, C59, C66-C68	CAP, .1UF, 10%, 25V, CERAMIC	C-495-.1
C28	CAP, 47P, 5%, 100V, CERAMIC	C-465-47P
C31, C50, C210	CAP, 100PF, 5%, 100V, CERAMIC	C-465-100P
C33, C63, C74, C93	CAP, .047U, 10%, 50V, CERAMIC	C-491-.047
C35	CAP, 22UF, 20%, 25V, TANTALUM	C-440-22
C4, C10	CAP, 15P, 1%, 100V, CERAMIC	C-512-15P
C43	CAP, .33UF, 10%, 50V, CERAMIC	C-464-.33
C44, C46, C124	CAP, .01UF, 10%, 50V, CERAMIC	C-491-.01
C45, C53	CAP, 1000P, 20%, 250V, CERAMIC	C-527-1000P
C5	CAP, .1UF, 20%, 100V, CERAMIC	C-436-.1
C51	CAP, 33PF, 10%, 1000V, CERAMIC	C-64-33P
C57, C58, C38, C48	CAP, 1000PF, 10%, 50V, MONO CERAMIC	C-452-1000P

Table 6-2 (continued)
Digital board parts list

Circuit Designation	Description	Keithley Part No.
C62, C91	CAP, 10UF, 20%, 25V, TANTALUM	C-440-10
C65	CAP, .022UF, 10%, 50V, CERAMIC	C-491-.022
C72, C86	CAP, 1UF, 20%, 50V, CERAMIC	C-519-1
C73, C64, C102	CAP, .1UF, 10%, 25V, CERAMIC	C-495-.1
C79, C81, C83, C84, C6, C7, C9, C18, C90, C52, C71	CAP, .1UF, 10%, 25V, CERAMIC	C-495-.1
C94	CAP, 470UF, -20+100%, 16V, ALUMINUM	C-313-470
C95, C106, C112, C118	CAP, 22UF, -10+100%, 35V, ELECTROLYTIC	C-309-22
C97	CAP, 1, 30% 250V, FILM	C-553-1
C99	CAP, .01UF, 20%, 50V, CERAMIC	C-418-.01
CR13, CR200, CR510	DIODE, DUAL HSM-2822T31	RF-95
CR14, CR15, CR22-CR24, CR5, CR32, CR33	DIODE, DUAL SWITCHING, BAV99L	RF-82
CR1-CR4, CR35, CR37, CR38, CR39, CR47	ULTRAFAST POWER RECTIFIER	RF-107
CR201, CR202, CR203, CR204, CR205	DIODE, DUAL COMMON ANODE, BAW56LT2	RF-98
CR210	SCHOTTKY BARRIER DIODE	RF-108
CR36,	DIODE, ULTRAFAST, MUR860 (TO-220AC)	RF-68
CR43-46	DUAL SCHOTTKY BARRIER RECTIFIER	RF-152
CR48, CR49	DIODE, SWITCHING, MMBD914	RF-83
CR6, CR12, CR40-41	DUAL SCHOTTKY BARRIER RECTIFIER	RF-153
CR7	DIODE, SWITCHING, MMSD914T19	RF-112
CR9	BRIDGE RECTIFIER	RF-120
F1	POLYSWITCH, SMD030-2	FU-103
F2	FUSE, 3A	FU-107-1
F3, F4, F5	FUSE, 1A	FU-109-1
HS1, HS2	HEAT SINK	HS-38
J1002	CONN, MOLEX, 3-PIN	CS-772-3
J1023	CONN, RIGHT ANGLE, 24-PIN	CS-507
J1024	CONN, RT ANGLE, MALE, 9-PIN	CS-761-9
J1025	CONN, MICRODIN W/GND FINGERS	CS-792
J1026	CONN, D-SUB MALE, BOARDLOCK TYPE	CS-848-9
K1	RELAY, SURFACE MOUNT	RL-188
L1	FERRITE CHIP, 600 OHM, BLM32A07	CH-62
L3	COMBINATION LINE FILTER CHOKE	CH-81
L4, L5, L6, L7	INDUCTOR	CH-89-1
LS1	BEEPER, 5V, 30MA, QMX-05	EM-6
P1027, P1033	CABLE ASSEMBLY	CA-62-4B

Table 6-2 (continued)
Digital board parts list

Circuit Designation	Description	Keithley Part No.
P1028	CABLE ASSEMBLY	CA-32-9B
P1035	LATCHING HEADER, FRICTON, SGL ROW	CS-724-3
PS1	POWER SUPPLY	PS-54-2A
Q1, Q3, Q4, Q5, Q6, Q200, Q201, Q202	TRANS, N-MOSFET, VN0605T	TG-243
Q10	TRANS, NPN, MMBT3904	TG-238
Q11	TRANS, HEXFET POWER MOSFET	TG-304
Q12, Q7	TRANS, HEXFET POWER MOSFET, IRF1540N	TG-382
Q13	TRANS, N-CHAN MOSFET, 2SK1412	TG-276
Q14	TRANS, PNP, MMBT3906L	TG-244
Q2	TRANS, HEXFET POWER MOSFET, IRFP450	TG-338
Q510	TRANS, P-CHAN, MOSFET, TP0610T	TG-259
Q8	POWER MOSFET, IRFIZ34G	TG-313
Q9	TRANS, TRIODE THYRISTOR, MAC223A6	TG-172
R1, R37, R43, R44, R45, R65	RES, 2.21K, 1%, 100MW, THICK FILM	R-418-2.21K
R10	RES, 332K, 1%, 100MW, THICK FILM	R-418-332K
R101, R67	RES, 20K, 1%, 100MW, THICK FILM	R-418-20K
R102	RES, 100K, 1%, 100MW, THICK FILM	R-418-100K
R103, R105	RES, 511, 1%, 100MW, THICK FILM	R-418-511
R108, R51	RES, 249K, 1%, 100MW, THICK FILM	R-418-249K
R111	RES, 357, 1%, 100MW, THICK FILM	R-418-357
R112	RES, 470K, 5%, 1W, FLAME PROOF	R-439-470K
R113	RES, 49.9K, 1%, 100MW, THICK FILM	R-418-49.9K
R116	RES, 4.99K, 1%, 100MW, THICK FILM	R-418-4.99K
R118	RES, 49.9K, 1%, 100MW, THICK FILM	R-418-49.9K
R121	RES, 215, 1%, 100MW, THICK FILM	R-418-215
R122, R100, R97	RES, 100, 1%, 100MW, THICK FILM	R-418-100
R15, R17, R21, R23, R31, R70, R72, R18, R48, R61	RES, 1K, 1%, 100MW, THICK FILM	R-418-1K
R2, R13, R4, R52, R14, R19, R34, R35, R50, R58	RES, 10K, 1%, 100MW, THICK FILM	R-418-10K
R201	RES, 8.06K, 1%, .1W, THICK FILM	R-418-8.06K
R202	RES, 6.04K, 1%, 100MW, THICK FILM	R-418-6.04K
R208, R214	RES, 2M, 1%, 100MW, THICK FILM	R-418-2M
R22, R206, R210	RES, 4.02K, 1%, 100MW, THICK FILM	R-418-4.02K
R25, R28, R49	RES, 4.75K, 1%, 100MW, THICK FILM	R-418-4.75K
R3	RES, 11K, 1%, 100MW, THICK FILM	R-418-11K
R30, R117	RES, 100, 1%, 100MW, THICK FILM	R-418-100
R33, R92, R95, 204	RES, .0499, 1%, 100MW, THICK FILM	R-418-.0499

Table 6-2 (continued)
Digital board parts list

Circuit Designation	Description	Keithley Part No.
R36, R47, R512	RES, 10K, 1%, 100MW, THICK FILM	R-418-10K
R38, R203, R207, R209, R212, R213, R6	RES, 10K, 1%, 100MW, THICK FILM	R-418-10K
R40, R32, R27, R24	RES, 5.1K, 5%, 125MW, METAL FILM	R-375-5.1K
R41, R56, R96, R98, R114, R115	RES, .1%, 1/10W, METAL FILM	R-168-498K
R46	RES, 10, 10%, 100MW, THICK FILM	R-418-10
R5	RES, 10M, 1%, 125MW, THICK FILM	R-418-10M
R510	RES, 249, 1%, 100MW, THICK FILM	R-418-249
R511	RES, 34K, 1%, 100MW, THICK FILM	R-418-34K
R55	RES, 10M, 1%, 125MW, THICK FILM	R-418-10M
R57	RES, 1M, 1%, 100MW, THICK FILM	R-418-1M
R59	RES, 475, 1%, 100MW, THICK FILM	R-418-475
R63, R68, R62, R75, R73, R74, R76, R78-R81, R83	RES, 10K, 1%, 100MW, THICK FILM	R-418-10K
R66	RES, 100K, 10%, 1W, METAL FILM	R-464-100K
R7, R69, R71, R85-R89, R26, R84, R109, R110	RES, 10K, 1%, 100MW, THICK FILM	R-418-10K
R77, R205, R211	RES, 15K, 1%, 100MW, THICK FILM	R-418-15K
R8, R155, R119, R200	RES, 1K, 1%, 100MW, THICK FILM	R-418-1K
R82	RES, 499, 1%, 100MW, THICK FILM	R-418-499
R9, R11, R12, R16, R20	RES, 100, 5%, 250MW, METAL FILM	R-376-100
R90	RES, 1.07K, 1%, 100MW, THICK FILM	R-418-1.07K
R93, R120	RES, 6.04K, .1%, .125W, THIN FILM	R-456-6.04K
R94	RES, .15, 1%, 30W	R-463-.15
R99, R107	RES, 150K, 1%, 100MW, THICK FILM	R-418-150K
RT101	INRUSH CURRENT LIMITER, ICL1516	RT-22
RT200, RT201	THERMISTER, PD=7MW/DEG C, 1500V, 613.74K	RT-8
RV1	JUNCTION TRANSIENT VOLT SUPPR, P4KE440	VR-10
RV101	METAL OXIDE VARISTOR, 275LA40	VR-7
S01, SO2	SOCKET, PLCC-032-T-A	SO-143-32
S1	SWITCH, PUSHBUTTON (6 POLE)	SW-466
T1	TRANSFORMER	TR-355A
T2	TRANSFORMER	TR-356A
T3	TRANSFORMER	TR-317A
TP3, TP4, TP6-7, TP-9, TP11-12, TP14, TP16-18	CONN, TEST POINT	CS-553
U3	IC, MICROCONTROLLER, MC68332-FC	LSI-161

Table 6-2 (continued)
Digital board parts list

Circuit Designation	Description	Keithley Part No.
U4	IC, +5V, RS-232, TRANSCEIVER, MAX202	IC-952
U5	IC, OP-AMP, AD705JR	IC-814
U6	IC, OCTAL INTER BUS TRANS, 75161	IC-647
U7	IC, PROTECTED QUAD POWER DRIVERS	IC-1212
U8	IC, POWER FACTOR CONTROLLER	IC-1113
U9	IC, HEX INVERTERS, 74HCT04	IC-880
U10, U27	IC, LOW POWER OPAMP, LMC7101AIM5	IC-980
U11, U41	IC, VOLT. COMPARATOR, LM393D	IC-775
U110	IC, 2 - INPUT AND GATE	IC-1140
U12, U14	IC, CMOS STATIC RAM	LSI-162-70
U13	IC, GPIB ADAPTER, 9914A	LSI-123
U15	PROGRAMMED ROM	2400-803*
U16	PROGRAMMED ROM	2400-804*
U17	IC, SERIAL EPROM, 24LC16B	LSI-153
U18	IC, REGULATOR SWITCHING, 78ST105SC	IC-1080
U2	IC, MICROMANAGER, DS12365-10	IC-884
U20	IC, OCTAL INTERFACE BUS, 75160	IC-646
U21	IC, DUAL POWRE MOSFET DRIVER, TSC426	IC-437
U22, U1	IC, DUAL D-TYPE F/F, 74HC74	IC-773
U23, U25, U29	IC, POS NAND GATES/INVERT, 74HCT14	IC-656
U24	IC, TRIPLE 3 IN NAND, 74F10	IC-659
U26	IC, VOLTAGE REGULATOR, LM340-12	IC-60
U28	IC, POWER VOLT REF, LT1004CZ 2.5	IC-929
VR1	DIODE, ZENER, 30V, BZX84C30	DZ-106-30
VR2	ZENER REGULATOR DIODE	DZ-120
Y1	CRYSTAL, FSM327	CR-41

*Order current firmware revision, for example: 2400-803C21. Both ROMs must be same revision level.

Table 6-3
Display board parts list

Circuit Designation	Description	Keithley Part No.
C901	CAP, 22UF, 20%, 6.3 TANTALUM	C-417-22
C902, C904, C907, C908, C910	CAP, .1UF, 20%, 100V, CERAMIC	C-436-.1
C903, C905, C906, C909, C911	CAP, .1UF, 20%, 50V, CERAMIC	C-418-.1
C912	CAP, 2.2UF, 20%, 100V, ALUM ELEC	C-503-2.2
C913, C914	CAP, 100UF, 20%, 16V, TANTALUM	C-504-100
C915, C916	CAP, 33PF, 10%, 100V, CERAMIC	C-451-33P
CR901, CR902, CR903, CR904	DIODE, SWITCHING, 250MA, BAV103	RF-89
CR905, CR906	DIODE, SWITCHING, MMBD914	RF-83
DS901	VACUUM FLUORESCENT DISPLAY	DD-51C
J1032	CONN, BERG	CS-339
J1033	CONN, HEADER STRAIGHT SOLDER PIN	CS-368-16
Q901, Q902	TRANS, NPN GEN PURPOSE, BC868	TG-293
R901	RES NET, 15K, 2%, 1.875W	TF-219-15K
R902	RES, 13K, 5%, 125MW, METAL FILM	R-375-13K
R903, R904	RES, 4.7K, 5%, 250MW, METAL FILM	R-376-4.7K
R905	RES, 1M, 5%, 125MW, METAL FILM	R-375-1M
R906	RES, 1K, 5%, 250MW, METAL FILM	R-376-1K
R907	RES, 240, 5%, 250MW, METAL FILM	R-376-240
R908	RES, 10M, 5%, 125MW, METAL FILM	R-375-10M
T901	TRANSFORMER, TDK, ER14.5 SERIES	TR-300
U901, U904, U905	IC, LATCHED DRIVERS, UCN-5812EPF-1	IC-732
U902	PROGRAMMED IC	7001-800*
U903	IC, 32-BIT, SERIAL, UCN5818EPF-1	IC-830
VR901	DIODE, ZENER, 8.2V, MMBZ5237	DZ-92
Y901	CRYSTAL, 4MHZ	CR-36-4M

*Order current firmware revision, for example: 7001-800A02.

Table 6-4
Miscellaneous parts list

Qty.	Description	Keithley Part No.
1	5X20MM SLO-BLO FUSE	FU-106-3.15
4	BANANA JACK, PUSH-IN, BLACK	BJ-14-0
1	BANANA JACK, PUSH-IN, BLUE	BJ-14-6
4	BANANA JACK, PUSH-IN, RED	BJ-14-2
1	BANANA JACK, PUSH-IN, WHITE	BJ-14-9
1	BEZEL, REAR	428-303D
1	BOTTOM SHIELD	2420-309A
1	CHASSIS	2420-301B
4	CHOKE	CH-58-1A
1	COVER	2420-317A
1	DISPLAY LENS	2440-311A
1	FAN	FN-33-2
2	FOOT	428-319A
2	FOOT, EXTRUDED	FE-22A
2	FOOT, RUBBER	FE-6
1	FRONT PANEL	2400-318B
1	HANDLE	428-329F
1	HEAT SINK	2420-308B
2	HOLDER, FERRITE	2001-367A
1	LED, HIGH POWER	PL-94
1	LENS, LED	6517-309B
1	LINE CORD	CO-7
1	LINE FILTER	LF-11
1	MEMBRANE SWITCH, FRONT	2440-313A
1	MOUNTING EAR, LEFT	428-338B
1	MOUNTING EAR, RIGHT	428-328E
1	POWER ROD	704-313A
1	REAR PANEL	2400-303B
5	STANDOFF	ST-154-4
1	SWITCHPAD	2400-315A
1	TEST LEAD	CA-23

A Specifications

SOURCE SPECIFICATIONS¹

VOLTAGE PROGRAMMING ACCURACY (Local or Remote Sense)

MODEL	RANGE	PROGRAMMING RESOLUTION	ACCURACY (1 Year)	NOISE
			23°C ±5°C ±(% rdg. + volts)	(peak-peak) 0.1Hz – 10Hz
ALL:	200.000 mV	5 µV	0.02% + 600 µV	5 µV (10µV 2430, 2440)
	2.00000 V	50 µV	0.02% + 600 µV	50 µV
2400 Only:	20.0000 V	500 µV	0.02% + 2.4 mV	500 µV
	200.000 V	5 mV	0.02% + 24 mV	5 mV
2410 Only:	20.0000 V	500 µV	0.02% + 2.4 mV	500 µV
	1000.00 V	50 mV	0.02% + 100 mV	20 mV
2420 Only:	20.0000 V	500 µV	0.02% + 2.4 mV	500 µV
	60.0000 V	1.5 mV	0.02% + 7.2 mV	1.5 mV
2425 and 2430 Only:	20.0000 V	500 µV	0.02% + 2.4 mV	500 µV
	100.0000 V	2.5 mV	0.02% + 12 mV	2.5 mV
2440 Only:	10.0000 V	500 µV	0.02% + 1.2 mV	250 µV
	40.0000 V	5 mV	0.02% + 4.8 mV	1 mV

TEMPERATURE COEFFICIENT (0°–18°C & 28°–50°C): ±(0.15 × accuracy specification)/°C.

MAX. OUTPUT POWER: 22W (66W for Model 2420, 110W for Model 2425 and 2430, 55W for Model 2440), four quadrant source or sink operation.

SOURCE/SINK LIMITS: **Model 2400:** ±21V @ ±1.05A, ±210V @ ±105 mA.

Model 2410: ±21V @ ±1.05A, ±1100V @ ±21 mA.

Model 2420: ±21V @ ±3.15A, ±63V @ ±1.05A.

Model 2425: ±21V @ ±3.15A, ±105V @ ±1.05A.

Model 2430: ±105V @ ±1.05A, ±105V @ ±10.5A (pulse mode only).

Model 2440: ±10.5V @ ±5.25A, ±42V @ ±1.05A.

VOLTAGE REGULATION: **Line:** 0.01% of range. **Load:** 0.01% of range + 100µV.

NOISE 10Hz–1MHz (p-p): 10mV (50mV typ., Models 2430 and 2440).

OVER VOLTAGE PROTECTION: User selectable values, 5% tolerance. Factory default = none.

CURRENT LIMIT: Bipolar current limit (compliance) set with single value. Min. 0.1% of range.

OVERSHOOT: <0.1% typical (full scale step, resistive load, 10mA range).

CURRENT PROGRAMMING ACCURACY (Local or Remote Sense)

MODEL	RANGE	PROGRAMMING RESOLUTION	ACCURACY (1 Year) ³	NOISE
			23°C ±5°C ±(% rdg. + amps)	(peak-peak) 0.1Hz – 10Hz
2400, 2410:	1.00000 µA	50 pA	0.035% + 600 pA	5 pA
ALL:	10.0000 µA	500 pA	0.033% + 2 nA	5 nA
	100.000 µA	5 nA	0.031% + 20 nA	50 nA
	1.00000 mA	50 nA	0.034% + 200 nA	500 nA
2400, 2420, 2425, 2430, 2440:	10.0000 mA	500 nA	0.045% + 2 µA	50 µA
2410 Only:	20.0000 mA	500 nA	0.045% + 4 µA	200 nA
ALL:	100.000 mA	5 µA	0.066% + 20 µA	1 µA
2400, 2410:	1.00000 A ²	50 µA	0.27% + 900 µA	100 µA
2420, 2425, 2430, 2440:	1.00000 A	50 µA	0.067% + 900 µA	50 µA
2420, 2425:	3.00000 A ²	150 µA	0.059% + 2.7 mA	150 µA
2430:	3.00000 A ² / ₄	500 µA	0.059% + 2.8 mA	300 µA
	10.00000 A ⁴			
2440:	5.00000 A	50 µA	0.10% + 5.4 mA	500 µA

TEMPERATURE COEFFICIENT (0°–18°C & 28°–50°C): ±(0.15 × accuracy specification)/°C.

MAX. OUTPUT POWER: 22W (66W for Model 2420, 110W for Model 2425 and 2430, 55W for Model 2440), four quadrant source or sink operation.

SOURCE/SINK LIMITS: **Model 2400:** ±1.05A @ ±21V, ±105 mA @ ±210V.

Model 2410: ±1.05A @ ±21V, ±21 mA @ ±1100V.

Model 2420: ±3.15A @ ±21V, ±1.05A @ ±63V.

Model 2425: ±3.15A @ ±21V, ±1.05A @ ±105V.

Model 2430: ±1.05A @ ±105V, ±10.5A @ ±105V (pulse mode only).

Model 2440: ±5.25A @ ±10.5V, ±1.05A @ ±42V.

CURRENT REGULATION: Line: 0.01% of range. **Load:** 0.05% of range (except Model 2440 5A range 0.05%) + 100pA.

VOLTAGE LIMIT: Bipolar voltage limit (compliance) set with single value. Min. 0.1% of range.

OVERSHOOT: <0.1% typical (1mA step, RL = 10k Ω , 20V range for Model 2400, 2410, 2420, 2425, 2430), (10V range for Model 2440).

1 **2400, 2410 Only:** Specifications valid for continuous output currents below 105mA. For operation above 105mA continuous for > 1 minute, derate accuracy 10%/35mA above 105mA.

2 Full operation (1A) regardless of load to 30°C (50°C for Model 2420, 2440). Above 30°C (50°C for Model 2420, 2440) ambient, derate 35mA/°C and prorate 35mA/ Ω load. 4-wire mode. For current sink operation on 1A, 3A, or 5A ranges, maximum continuous power is limited to approximately 1/2 rated power or less, depending on current, up to 30°C ambient. See power equations in the User's Manual to calculate allowable duty cycle for specific conditions.

3 For sink mode, 1 μ A to 100mA range, accuracy is:

Model 2400: $\pm(0.15\% + \text{offset}^*4)$

Models 2410, 2420, 2425, 2430, 2440: $\pm(0.5\% + \text{offset}^*3)$

For 1A range, accuracy is:

Model 2400: $\pm(1.5\% + \text{offset}^*8)$

Models 2410, 2420, 2425, 2430, 2440: $\pm(1.5\% + \text{offset}^*3)$

4 10A range only in pulse mode. Limited to 2.5ms pulse width maximum. 10% duty cycle maximum.

ADDITIONAL SOURCE SPECIFICATIONS

TRANSIENT RESPONSE TIME: 30 μ s minimum for the output to recover to its spec. following a step change in load.

COMMAND PROCESSING TIME: Maximum time required for the output to begin to change following the receipt of :SOURce:VOLTage|CURRent <nrf> command. **Autorange On:** 10ms. **Autorange Off:** 7ms.

OUTPUT SETTling TIME: Time required to reach 0.1% of final value after command is processed. 100 μ s typical. Resistive load. 10 μ A to 100mA range.

OUTPUT SLEW RATE ($\pm 30\%$):

Model 2400: 0.5V/ μ s, 200V range, 100mA compliance.
0.08V/ μ s, 20V range, 100mA compliance.

Model 2410: 0.5V/ μ s, 1000V range, 20mA compliance.
0.08V/ μ s, 20V range, 100mA compliance.

Model 2420: 0.14V/ μ s, 60V range, 100mA compliance.
0.08V/ μ s, 20V range, 100mA compliance.

Model 2425, 2430: 0.25V/ μ s, 100V range, 100mA compliance.
0.08V/ μ s, 20V range, 100mA compliance.

Model 2440: 0.25V/ μ s, 40V range, 100mA compliance.
0.08V/ μ s, 10V range, 100mA compliance.

DC FLOATING VOLTAGE: Output can be floated up to ± 250 VDC (Model 2440 ± 40 VDC) from chassis ground.

REMOTE SENSE: Up to 1V drop per load lead.

COMPLIANCE ACCURACY: Add 0.3% of range and $\pm 0.02\%$ of reading to base specification.

OVER TEMPERATURE PROTECTION: Internally sensed temperature overload puts unit in standby mode.

RANGE CHANGE OVERSHOOT: Overshoot into a fully resistive 100k Ω load, 10Hz to 1MHz BW, adjacent ranges: 100mV typical, except 20V/200V (20V/60V on Model 2420), 20V/100V on Model 2425 and 2430, range boundary, and Model 2440.

MINIMUM COMPLIANCE VALUE: 0.1% of range.

ADDITIONAL PULSE MODE SOURCE SPECIFICATIONS

MAXIMUM DUTY CYCLE: 8%, hardware limited, 10A range only. All other ranges 100%.

MAXIMUM PULSE WIDTH: 5ms from 90% rising to 90% falling edge, 2.5ms 10A range.

MINIMUM PULSE WIDTH: 150 μ s.

MINIMUM PULSE RESOLUTION: 50 μ s typical, 70 μ s max., limited by system jitter.

SOURCE ACCURACY: Determined by settling time and source range specifications.

OUTPUT SETTling TIME 0.1%:

800 μ s typ., source I = 10A into 10 Ω , limited by voltage slew rate.

500 μ s typ., source I = 10A into 1 Ω , limited by voltage slew rate.

OUTPUT SLEW RATE:

Voltage (10 Ω load): 0.25V/ μ s $\pm 30\%$ on 100V range
0.08V/ μ s $\pm 30\%$ on 20V range, 10A range.

Current (0 Ω load): 0.25A/ μ s $\pm 30\%$ on 100V range
0.08A/ μ s $\pm 30\%$ on 20V range, 10A range.

MEASURE SPECIFICATIONS^{1,2,7}

VOLTAGE MEASUREMENT ACCURACY (Local or Remote Sense)

MODEL	RANGE	DEFAULT RESOLUTION	INPUT RESISTANCE	ACCURACY (1 Year)
				23°C ±5°C ±(% rdg. + volts)
ALL:	200.000 mV	1 µV	>10 GΩ	0.012% + 300 µV
	2.00000 V	10 µV	>10 GΩ	0.012% + 300 µV
2400:	20.0000 V	100 µV	>10 GΩ	0.015% + 1.5 mV
	200.000 V	1 mV	>10 GΩ	0.015% + 10 mV
2410:	20.0000 V	100 µV	>10 GΩ	0.015% + 1 mV
	1000.00 V	10 mV	>10 GΩ	0.015% + 50 mV
2420, 2425, 2430:	20.0000 V	100 µV	>10 GΩ	0.015% + 1 mV
2420:	60.0000 V	1 mV	>10 GΩ	0.015% + 3 mV
	100.0000 V	1 mV	>10 GΩ	0.015% + 5 mV
2440:	10.0000 V	100 µV	>10 GΩ	0.015% + 750 µV
	40.0000 V	1 mV	>10 GΩ	0.015% + 3 mV

TEMPERATURE COEFFICIENT (0°–18°C & 28°–50°C): ±(0.15 × accuracy specification) /°C.

CURRENT MEASUREMENT ACCURACY (Local or Remote Sense)

MODEL	RANGE	DEFAULT RESOLUTION	VOLTAGE BURDEN ³	ACCURACY (1 Year)
				23°C ±5°C ±(% rdg. + amps)
2400, 2410:	1.00000 µA	10 pA	< 1mV	0.029% + 300 pA
All:	10.0000 µA	100 pA	< 1mV	0.027% + 700 pA
	100.000 µA	1 nA	< 1mV	0.025% + 6 nA
	1.00000 mA	10 nA	< 1mV	0.027% + 60 nA
	10.0000 mA	100 nA	< 1mV	0.035% + 600 nA
2400, 2420, 2425, 2430, 2440:	20.0000 mA	100 nA	< 1mV	0.035% + 1.2 µA
All:	100.000 mA	1 µA	< 1mV	0.055% + 6 µA
2400, 2410:	1.00000 A	10 µA	< 1mV	0.22% + 570 µA
2420, 2425, 2430, 2440:	1.00000 A	10 µA	< 1mV	0.060% + 570 µA
2420, 2425:	3.00000 A	10 µA	< 1mV	0.052% + 1.71 mA
	10.0000 A ⁶	10 µA	< 1mV	0.052% + 1.71 mA
2440:	5.00000 A	10 µA	< 1mV	0.10% + 3.42 mA

TEMPERATURE COEFFICIENT (0°–18°C & 28°–50°C): ±(0.10 × accuracy specification) /°C.

RESISTANCE MEASUREMENT ACCURACY (Local or Remote Sense)

RANGE	DEFAULT RESOLUTION	DEFAULT TEST CURRENT		2400	NORMAL ACCURACY (23°C ±5°C) 1 YEAR, ±(% rdg. + ohms)	2420, 2425, 2430, 2440
		2400, 2410	2420, 2425, 2430, 2440			
<0.20000 Ω ⁴	–	–	–	Source I _{ACC} + Meas.V _{ACC}	Source I _{ACC} + Meas.V _{ACC}	Source I _{ACC} + Meas.V _{ACC}
2.00000 Ω ⁴	10 µΩ	–	1 A	Source I _{ACC} + Meas.V _{ACC}	Source I _{ACC} + Meas.V _{ACC}	0.17% + 0.0003 Ω
20.0000 Ω	100 µΩ	100 mA	100 mA	0.10% + 0.003 Ω	0.11% + 0.006 Ω	0.10% + 0.003 Ω
200.000 Ω	1 mΩ	10 mA	10 mA	0.08% + 0.03 Ω	0.09% + 0.1 Ω	0.08% + 0.03 Ω
2.00000 kΩ	10 mΩ	1 mA	1 mA	0.07% + 0.3 Ω	0.08% + 0.6 Ω	0.07% + 0.3 Ω
20.0000 kΩ	100 mΩ	100 µA	100 µA	0.06% + 3 Ω	0.07% + 6 Ω	0.06% + 3 Ω
200.000 kΩ	1 Ω	10 µA	10 µA	0.07% + 30 Ω	0.07% + 60 Ω	0.07% + 30 Ω
2.00000 MΩ ⁸	10 Ω	1 µA	1 µA	0.11% + 300 Ω	0.12% + 600 Ω	0.11% + 300 Ω
20.0000 MΩ ⁹	100 Ω	1 µA	1 µA	0.11% + 1 kΩ	0.12% + 2.4 kΩ	0.11% + 1 kΩ
200.000 MΩ ⁴	1 kΩ	100 nA	–	0.66% + 10 kΩ	0.66% + 24 kΩ	Source I _{ACC} + Meas.V _{ACC}
>200.000 MΩ ⁴	–	–	–	Source I _{ACC} + Meas.V _{ACC}	Source I _{ACC} + Meas.V _{ACC}	Source I _{ACC} + Meas.V _{ACC}

**ENHANCED
ACCURACY (23°C ±5°C)⁵
1 YEAR, ±(% rdg. + ohms)**

RANGE		2400
<0.20000	Ω ⁴	Source I _{ACC} + Meas. V _{ACC}
2.00000	Ω ⁴	Source I _{ACC} + Meas. V _{ACC}
20.0000	Ω	0.07% + 0.001 Ω
200.000	Ω	0.05% + 0.01 Ω
2.00000	kΩ	0.05% + 0.1 Ω
20.0000	kΩ	0.04% + 1 Ω
200.000	kΩ	0.05% + 10 Ω
2.00000	MΩ ⁸	0.05% + 100 Ω
20.0000	MΩ ⁹	0.05% + 500 Ω
200.000	MΩ ⁴	0.35% + 5 kΩ
>200.000	MΩ ⁴	Source I _{ACC} + Meas. V _{ACC}

TEMPERATURE COEFFICIENT (0°–18°C & 28°–50°C): ±(0.15 × accuracy specification)/°C.

SOURCE I MODE, MANUAL OHMS: Total uncertainty = I source accuracy + V measure accuracy (4-wire remote sense).

SOURCE V MODE, MANUAL OHMS: Total uncertainty = V source accuracy + I measure accuracy (4-wire remote sense).

6-WIRE OHMS MODE: Available using active ohms guard and guard sense. Max. Guard Output Current: 50mA (except 1A range). Accuracy is load dependent. Refer to White Paper no. 2033 for calculation formula.

GUARD OUTPUT IMPEDANCE: <0.1Ω in ohms mode.

¹ Speed = Normal (1 PLC). For 0.1 PLC, add 0.005% of range to offset specifications, except 200mV, 1A, 10A ranges, add 0.05%. For 0.01 PLC, add 0.05% of range to offset specifications, except 200mV, 1A, 10A ranges, add 0.5%.

² Accuracies apply to 2- or 4-wire mode when properly zeroed.

³ 4-wire mode.

⁴ Manual ohms only – except 2420, 2425, 2430, 2440 for 2Ω range and 2410 or 2400 for 200MΩ range.

⁵ Source readback enabled, offset compensation ON. Also available on 2410, 2420, 2425, 2430, and 2440 with similar accuracy enhancement.

⁶ 10A range only in pulse mode.

⁷ In pulse mode, limited to 0.1 PLC measurement.

⁸ Except 2440; default test current is 5μA.

⁹ Except 2440; default test current is 0.5μA.

CONTACT CHECK SPECIFICATIONS

SPEED: 350μs for verification and notification.

CONTACT CHECK:	2Ω	15Ω	50Ω
No contact check failure	<1.00Ω	<13.5Ω	<47.5Ω
Always contact check failure	>3.00Ω	>16.5Ω	>52.5Ω

SYSTEM SPEEDS

MEASUREMENT¹

MAXIMUM RANGE CHANGE RATE: 75/second.

MAXIMUM MEASURE AUTORANGE TIME: 40ms (fixed source)².

SWEEP OPERATION³ READING RATES (rdg./second) for 60Hz (50Hz):

SPEED	NPLC/ TRIGGER ORIGIN	MEASURE		SOURCE-MEASURE ⁵		SOURCE-MEASURE PASS/FAIL TEST ^{4,5}		SOURCE-MEMORY ⁴	
		TO MEM.	TO GPIB	TO MEM.	TO GPIB	TO MEM.	TO GPIB	TO MEM.	TO GPIB
Fast	0.01 / internal	2081 (2030)	1754	1551 (1515)	1369	902 (900)	981	165 (162)	165
IEEE-488.1 Mode	0.01 / external	1239 (1200)	1254	1018 (990)	1035	830 (830)	886	163 (160)	163
Fast	0.01 / internal	2081 (2030)	1198 (1210)	1551 (1515)	1000 (900)	902 (900)	809 (840)	165 (162)	164 (162)
IEEE-488.2 Mode	0.01 / external	1239 (1200)	1079 (1050)	1018 (990)	916 (835)	830 (830)	756 (780)	163 (160)	162 (160)
Medium	0.10 / internal	510 (433)	509 (433)	470 (405)	470 (410)	389 (343)	388 (343)	133 (126)	132 (126)
IEEE-488.2 Mode	0.10 / external	438 (380)	438 (380)	409 (360)	409 (365)	374 (333)	374 (333)	131 (125)	131 (125)
Normal	1.00 / internal	59 (49)	59 (49)	58 (48)	58 (48)	56 (47)	56 (47)	44 (38)	44 (38)
IEEE-488.2 Mode	1.00 / external	57 (48)	57 (48)	57 (48)	57 (47)	56 (47)	56 (47)	44 (38)	44 (38)

SINGLE READING OPERATION READING RATES (rdg./second) for 60Hz (50Hz):

SPEED	NPLC/T RIGGER ORIGIN	MEASURE TO GPIB	SOURCE-MEASURE ⁵ TO GPIB	SOURCE-MEASURE PASS/FAIL TEST ^{4,5}
				TO GPIB
Fast (488.1)	0.01 / internal	537	140	135
Fast (488.2)	0.01 / internal	256 (256)	79 (83)	79 (83)
Medium (488.2)	0.10 / internal	167 (166)	72 (70)	69 (70)
Normal (488.2)	1.00 / internal	49 (42)	34 (31)	35 (30)

COMPONENT INTERFACE HANDLER TIME for 60Hz (50Hz):^{4,6}

SPEED	NPLC/ TRIGGER ORIGIN	MEASURE TO GPIB	SOURCE PASS/FAIL TEST	SOURCE-MEASURE PASS/FAIL TEST ^{5,7}
				TO GPIB
Fast	0.01 / external	1.04 ms (1.08 ms)	0.5 ms (0.5 ms)	4.82 ms (5.3 ms)
Medium	0.10 / external	2.55 ms (2.9 ms)	0.5 ms (0.5 ms)	6.27 ms (7.1 ms)
Normal	1.00 / external	17.53 ms (20.9 ms)	0.5 ms (0.5 ms)	21.31 ms (25.0 ms)

¹ Reading rates applicable for voltage or current measurements. Auto zero off, autorange off, filter off, display off, trigger delay = 0, and binary reading format.

² Purely resistive load. 1 μ A and 10 μ A ranges <65ms.

³ 1000 point sweep was characterized with the source on a fixed range.

⁴ Pass/Fail test performed using one high limit and one low math limit.

⁵ Includes time to re-program source to a new level before making measurement.

⁶ Time from falling edge of START OF TEST signal to falling edge of END OF TEST signal.

⁷ Command processing time of :SOURce:VOLTage|CURRent:TRIGgered <nrf> command not included.

GENERAL**NOISE REJECTION:**

	NPLC	NMRR	CMRR
Fast	0.01	—	80 dB
Medium	0.1	—	80 dB
Slow	1	60 dB	100 dB ¹

¹ Except lowest 2 current ranges = 90dB.

LOAD IMPEDANCE: Stable into 20,000pF typical.

COMMON MODE VOLTAGE: 250V DC (40V DC for Model 2440).

COMMON MODE ISOLATION: >10⁹Ω, <1000pF

OVERRRANGE: 105% of range, source and measure.

MAX. VOLTAGE DROP BETWEEN INPUT/OUTPUT AND SENSE TERMINALS: 5V.

MAX. SENSE LEAD RESISTANCE: 1MΩ for rated accuracy.

SENSE INPUT IMPEDANCE: >10⁹Ω.

GUARD OFFSET VOLTAGE: <150μV, typical (300μV for Models 2430, 2440).

SOURCE OUTPUT MODES:

Pulse (Model 2430 only)

Fixed DC level

Memory List (mixed function)

Stair (linear and log)

SOURCE MEMORY LIST: 100 points max.

MEMORY BUFFER: 5,000 readings @ 5 digits (two 2,500 point buffers). Includes selected measured value(s) and time stamp. Lithium battery backup (3 yr+ battery life).

PROGRAMMABILITY: IEEE-488 (SCPI-1995.0), RS-232, 5 user-definable power-up states plus factory default and *RST.

DIGITAL INTERFACE:

Interlock: Active low input.

Handler Interface: Start of test, end of test, 3 category bits. +5V@ 300mA supply.

Digital I/O: 1 trigger input, 4 TTL/Relay Drive outputs (33V @ 500mA, diode clamped).

POWER SUPPLY: 100V to 240V rms, 50–60Hz (automatically detected at power up). **Model 2400:** 190VA. **Model 2410:** 210VA. **Model 2420:** 220VA. **Model 2425, 2430:** 250VA. **Model 2440:** 240VA.

COOLING: (Model 2410, 2420, 2425, 2430, 2440): Forced air, variable speed.

WARRANTY: 1 year.

EMC: Conforms to European Union Directive 89/336/EEC, EN 61326-1.

SAFETY: Conforms to European Union Directive 73/23/EEC, EN61010-1.

VIBRATION: MIL-PRF-28800F Class 3 Random.

WARM-UP: 1 hour to rated accuracies.

DIMENSIONS: 89mm high × 213mm wide × 370mm deep (3½ in × 8½ in × 14⅞ in). **Bench Configuration (with handle & feet):** 104mm high × 238mm wide × 370mm deep (4¼ in × 9¼ in × 14⅞ in).

WEIGHT: 3.21kg (7.08 lbs) (Model 2425, 2430, 2440: 4.1kg, 9.0 lbs).

ENVIRONMENT:

Operating: 0°–50°C, 70%R.H. up to 35°C. Derate 3% R.H./°C, 35°–50°C.

Storage: –25°C to 65°C.

ACCESSORIES SUPPLIED: Model 1754 Universal Test Lead Kit, User's Manual, Service Manual, LabVIEW and TestPoint Drivers.

Specifications subject to change without notice.

SourceMeter® is a registered trademark of Keithley Instruments, Inc. All other trademarks are the property of their respective companies.

Accuracy calculations

The information below discusses how to calculate accuracy for both measurement and source functions.

Measurement accuracy

Measurement accuracy is calculated as follows:

Accuracy = $\pm(\% \text{ of reading} + \text{offset})$

As an example of how to calculate the actual reading limits, assume that you are measuring 10V on the 20V range. You can compute the reading limit range from one-year measure voltage accuracy specifications as follows:

Accuracy = $\pm(\% \text{ of reading} + \text{offset})$
 $\pm[(0.015\% \times 10\text{V}) + 1\text{mV}]$
 $\pm(1.5\text{mV} + 1\text{mV})$
 $\pm 2.5\text{mV}$

Thus, the actual reading range is: $10\text{V} \pm 2.5\text{mV}$, or from 9.9975 to 10.0025V

Current measurement calculations are performed in exactly the same manner using the pertinent specifications, ranges, and input signal values.

Source accuracy

Source accuracy is calculated similarly, except of course that source specifications are used. As an example of how to calculate the actual source output limits, assume that you are sourcing 0.7mA on the 1mA source range. You can compute the reading limit range from source current one-year accuracy specifications as follows:

Accuracy = $\pm(0.034\% \text{ of output} + 200\text{nA offset})$
 $\pm[(0.034\% \times 0.7\text{mA}) + 200\text{nA}]$
 $\pm(238\text{nA} + 200\text{nA})$
 $\pm 438\text{nA}$

In this case, the actual current output range is: $0.7\text{mA} \pm 438\text{nA}$, or from 0.69956mA to 0.70044mA.

B Command Reference

Introduction

This appendix contains detailed information on the various Model 2440 remote calibration commands, calibration error messages, and methods to detect the end of each calibration step.

Section 2 of this manual covers detailed calibration procedures.

Command summary

Table B-1 summarizes Model 2440 calibration commands. These commands are covered in detail in the following paragraphs.

Table B-1

Remote calibration command summary

Command	Description
:CALibration	Calibration subsystem.
:PROTeCted	Cal commands protected by password.
:CODE '<password>'	Unlock cal; if cal is unlocked, changes password. (Default password: KI002440.)
:COUNT?	Query number of times 2440 has been calibrated.
:SAVE	Save calibration data to EEPROM.*
:LOCK	Lock calibration, inhibit SAVE command operation.
:LOCK?	Request cal lock status. (0 = unlocked; 1 = locked.)
:DATE <y>,<m>,<d>	Program calibration year, month, day.
:DATE?	Query calibration year, month, day.
:NDUE <y>,<m>,<d>	Program calibration due year, month, day.
:NDUE?	Query calibration due year, month, day.
:SENSe <nrf>	Calibrate active measure range.
:DATA?	Query measurement cal constants for active range.
:SOURce <nrf>	Calibrate active source range.
:DATA?	Query source cal constants for active range.

*Calibration data will not be saved if:

1. Calibration was not unlocked with :CODE command.
2. Invalid data exists. (For example, cal step failed or was aborted.)
3. Incomplete number of cal steps were performed. (For example, omitting a negative full-scale step.)
Ranges that were successfully calibrated will be saved if calibration is unlocked. Ranges that failed will not be saved.

Miscellaneous commands

Miscellaneous commands are those commands that perform such functions as saving calibration constants, locking out calibration, and programming date parameters.

CODE

(:CALibration:PROTected:CODE)

Purpose	To unlock calibration so that you can perform the calibration procedures.
Format	:cal:prot:code '<password>'
Parameters	Up to a 8-character string including letters and numbers.
Description	The :CODE command sends the password and enables calibration when performing these procedures via remote. The correct password must be sent to the unit before sending any other calibration command. The default remote password is KI002440.

- NOTE**
- *The :CODE command should be sent only once before performing calibration. Do not send :CODE before each calibration step.*
 - *To change the code, first send the present code, then send the new code.*
 - *The password parameter must be enclosed in single quotes.*
 - *If you change the first two characters of the password to something other than “KI”, you will not be able to unlock calibration from the front panel.*

Example :CAL:PROT:CODE 'KI002440' Send default code of KI002440.

COUNT?

(:CALibration:PROTected:COUNT?)

Purpose	To request the number of times the Model 2440 has been calibrated.
Format	:cal:prot:count?
Response	Number of times calibrated.
Description	The :COUNT? query may be used to determine the total number of times the Model 2440 has been calibrated.
Example	:CAL:PROT:COUNT? Request calibration count.

LOCK

(:CALibration:PROTeCted:LOCK)

Purpose	To lock out calibration.	
Format	:cal:prot:lock	
Query	:cal:prot:lock?	
Response	0	Calibration unlocked
	1	Calibration locked
Description	The :LOCK command allows you to lock out comprehensive calibration after completing those procedures. Thus, :LOCK performs the opposite of sending the password with the :CODE command. The :LOCK? query returns calibration lock status.	

NOTE *To unlock calibration, send the :CODE command with the appropriate password.*

Example :CAL:PROT:LOCK Lock out calibration

SAVE

(:CALibration:PROTeCted:SAVE)

Purpose	To save calibration constants in EEROM after the calibration procedure.	
Format	:cal:prot:save	
Description	The :SAVE command stores internally calculated calibration constants derived during comprehensive in EEROM. EEROM is non-volatile memory, and calibration constants will be retained indefinitely once saved. Generally, :SAVE is sent after all other calibration steps (except for :LOCK).	

NOTE *Calibration will be only temporary unless the :SAVE command is sent to permanently store calibration constants. Calibration data will not be saved if: (1) calibration was not unlocked by sending the :CODE command, (2) invalid data exists (for example, cal step failed or was aborted.), or (3) an incomplete number of cal steps were performed (for example, omitting a negative full-scale step).*

Example :CAL:PROT:SAVE Save calibration constants

DATE

(:CALibration:PROTected:DATE)

Purpose	To program the calibration date.
Format	:cal:prot:date <year>, <month>, <day>
Parameters	<year> = 2000 to 2099 <month> = 1 to 12 <day> = 1 to 31
Query	:cal:prot:date?
Response	<year>, <month>, <day>
Description	The :DATE command allows you to store the calibration date in instrument EEROM for future reference. You can read back the date from the instrument by using the :DATE? query, or by using the front panel CAL menu.

NOTE The year, month, and day parameters must be delimited by commas.

Example :CAL:PROT:DATE 2001,2,20 Send cal date (2/20/2001).

NDUE

(:CALibration:PROTected:NDUE)

Purpose	To send the next calibration due date to the instrument.
Format	:cal:prot:ndue <year>, <month>, <day>
Parameters	<year> = 2000 to 2099 <month> = 1 to 12 <day> = 1 to 31
Query	:cal:prot:ndue?
Response	<year>, <month>, <day>
Description	The :NDUE command allows you to store the date when calibration is next due in instrument memory. You can read back the next due date by using the :NDUE? query, or by using the front panel CAL menu.

NOTE The next due date parameters must be delimited by commas.

Example :CAL:PROT:NDUE 2002,2,20 Send due date (2/20/2002).

SENSE

(:CALibration:PROTeCted:SENSe)

Purpose To calibrate the sense function.

Format :cal:prot:sens <nrf>

Parameters See [Table B-2](#) for recommended parameter ranges for optimum calibration.

Description The :CAL:PROT:SENS command calibrates the Model 2440 sense function. To use this command, you must (1) program the source to the correct value, (2) select the range being calibrated, and (3) send the :CAL:PROT:SENS command for each parameter listed in [Table B-2](#).

NOTE *When the Model 2440 receives this command, it will attempt to place the parameter into one of the three parameter ranges summarized in [Table B-2](#), depending on the active :SENS:FUNC and range. If the parameter does not fit into any of the three allowed ranges, an error number -222, “Parameter data out of range” will be generated. Once the unit has successfully selected the appropriate parameter range, it will then check to see if autorange for the active :SENS:FUNC is enabled. If so, an error number -221, “Settings conflict” will be generated. If no error occurs, the active sense function/range point will be calibrated using the corresponding parameter.*

Note that parameters for a given sense function and range may be sent in any order; however, once one :CAL:PROT:SENS command executes, the other two must also be executed, or an error number -200, “Execution error” will occur when the :CAL:PROT:SAVE command is processed at the end of the calibration procedure.

Example :CAL:PROT:SENS 2 Calibrate 2V sense range.

Table B-2

Recommended :CALibration:PROTECTED:SENSe parameter ranges

Sense range	First parameter (zero)	Second parameter (negative full scale)	Third parameter (positive full scale)
0.2V	0.002 to +0.002	-0.18 to -0.22	+0.18 to +0.22
2V	0.02 to +0.02	-1.8 to -2.2	+1.8 to +2.2
10V	0.1 to +0.1	-9 to -11	+9 to +11
40V	0.5 to +0.5	-35 to -42	+35 to +42
10µA	-1E-7 to +1E-7	-9E-6 to -11E-6	+9E-6 to +11E-6
100µA	-1E-6 to +1E-6	-90E-6 to -110E-6	+90E-6 to +110E-6
1mA	-1E-5 to +1E-5	-0.9E-3 to -1.1E-3	+0.9E-3 to +1.1E-3
10mA	-1E-4 to +1E-4	-9E-3 to -11E-3	+9E-3 to +11E-3
100mA	-1E-3 to +1E-3	-90E-3 to -110E-3	+90E-3 to +110E-3
1A	-1E-2 to +1E-2	-0.9 to -1.1	+0.9 to +1.1
5A	-5E-2 to 5E-2	-4.75 to -5.25	+4.75 to +5.25

Note: Actual allowable parameter ranges are $\pm 50\%$ of full range for zero parameters, 75% of full scale to 150% of full scale for full-range parameters, but ranges listed above should be observed for optimum calibration.

SOURCE

(:CALibration:PROTECTED:SOURce)

Purpose To calibrate the source function.

Format :cal:prot:sour <nrf>

Parameters See [Table B-3](#) for recommended parameter ranges.

Description The :CAL:PROT:SOUR command calibrates the Model 2440 source function. To use this command, you must (1) program the source to the correct value, (2) select the range being calibrated, and (3) send the :CAL:PROT:SOUR command for each parameter listed in [Table B-3](#).

NOTE When the Model 2440 receives this command, it will attempt to place the parameter into one of the four parameter ranges summarized in Table B-3, depending on the active `:SOUR:FUNC` and range. If the parameter does not fit into any of the four allowed ranges, an error number -222, “Parameter data out of range” will be generated. Once the unit has successfully selected the appropriate parameter range, it will then check to see if the active source is programmed to a value within the selected parameter range, and that `:OUTP:STAT` is ON. If the active source is not programmed to a value within the parameter range (or if the source is in autorange or in standby), an error number -221, “Settings conflict” will be generated. If no error occurs, the active source function/range point will be calibrated using the corresponding parameter.

Note that parameters for a given source function and range may be sent in any order; however, once one `:CAL:PROT:SOUR` command executes, the other three must also be executed, or an error number -200, “Execution error” will occur when the `:CAL:PROT:SAVE` command is processed at the end of the calibration procedure.

Because the source is calibrated for both positive and negative values, two zero calibration points are required. The Model 2440 automatically uses the appropriate zero parameter based on whether the source polarity is positive or negative.

Example `:CAL:PROT:SOUR 2` Calibrate 2V source range.

Table B-3

Recommended :CALibration:PROTected:SOURce parameter ranges

Source range	First parameter (negative full scale)	Second parameter (negative zero)	Third parameter (positive full scale)	Fourth parameter (positive zero)
0.2V	-0.18 to -0.22	-0.002 to +0.002	+0.18 to +0.22	-0.002 to +0.002
2V	-1.8 to -2.2	-0.02 to +0.02	+1.8 to +2.2	-0.02 to +0.02
10V	-9 to -11	-0.1 to +0.1	+9 to +11	-0.1 to +0.1
40V	-35 to -42	-0.5 to +0.5	+35 to +42	-0.5 to +0.5
10µA	-9E-6 to -11E-6	-1E-7 to +1E-7	+9E-6 to +11E-6	-1E-7 to +1E-7
100µA	-90E-6 to -110E-6	-1E-6 to +1E-6	+90E-6 to +110E-6	-1E-6 to +1E-6
1mA	-0.9E-3 to -1.1E-3	-1E-5 to +1E-5	+0.9E-3 to +1.1E-3	-1E-5 to +1E-5
10mA	-9E-3 to -11E-3	-1E-4 to +1E-4	+9E-3 to +11E-3	-1E-4 to +1E-4
100mA	-90E-3 to -110E-3	-1E-3 to +1E-3	+90E-3 to +110E-3	-1E-3 to +1E-3
1A	-0.9 to -1.1	-1E-2 to +1E-2	+0.9 to +1.1	-1E-2 to +1E-2
5A	-4.75 to -5.25	-5E-2 to +5E-2	+4.75 to +5.25	-5E-2 to +5E-2

Note: Actual allowable parameter ranges are $\pm 50\%$ of full range for zero parameters, 75% of full scale to 150% of full scale for full-range parameters, but ranges listed above should be observed for optimum calibration.

DATA?

(:CALibration:PROTeCted:SENSe:DATA?)
 (:CALibration:PROTeCted:SOURce:DATA?)

Purpose	To request the calibration constants for the active range.
Format	:cal:prot:sens:data? :cal:prot:sour:data?
Response	Four comma-separated ASCII floating-point constants
Description	The :CAL:PROT:SENS:DATA? and :CAL:PROT:SOUR:DATA? queries request the calibration constants for the active range of the sense and source functions respectively. The four returned constants are in ASCII floating-point format delimited by commas.

NOTE To request the appropriate constants, (1) select the source or sense function, (2) choose the desired range, and (3) send the desired :DATA? query.

Example	:SENS:FUNC 'VOLT:DC'	Select DC sense function.
	:SENS:VOLT:DC:RANGE 0.2	Choose 200mV range.
	:CAL:PROT:SENS:DATA?	Request cal constants.

Detecting calibration errors

If an error occurs during any calibration step, the Model 2440 will generate an appropriate error message. Several methods to detect calibration errors are discussed below.

Reading the error queue

As with other Model 2440 errors, any calibration errors will be reported in the error queue. (You can read the error queue by using the :SYST:ERR? query.)

Error summary

Table B-4 summarizes calibration errors. These errors will occur under the following conditions.

Error 500/501 — These errors will occur if you do not set the calibration date or calibration due date.

Error 502 — This error will occur when the :CAL:PROT:SENS or :CAL:PROT:SOUR command is sent with a parameter that cannot be placed into any of the defined numeric ranges.

Error 503/504 — Will occur when the source/compliance DAC calibration constants generate an invalid DAC setting. All of the source/compliance DAC calibration constants are verified each time a :CAL:PROT:SOUR command is processed and when the Model 2440 is first turned on. This error generally occurs when the Model 2440 source circuitry is defective.

Error 505 — Will occur when a :CAL:PROT:SOUR command generates an invalid source offset calibration constant.

Error 506 — Will occur when a :CAL:PROT:SOUR command generates an invalid source gain calibration constant.

Error 507 — Will occur when a :CAL:PROT:SENS command generates an invalid measurement offset calibration constant.

Error 508 — Will occur when a :CAL:PROT:SENS command generates an invalid measurement gain calibration constant.

Table B-4

Calibration errors

Error number	Error message
+500	“Date of calibration not set”
+501	“Next date of calibration not set”
+502	“Calibration data invalid”
+503	“DAC calibration overflow”
+504	“DAC calibration underflow”
+505	“Source offset data invalid”
+506	“Source gain data invalid”
+507	“Measurement offset data invalid”
+508	“Measurement gain data invalid”

Status byte EAV (Error Available) bit

Whenever an error is available in the error queue, the EAV (Error Available) bit (bit 2) of the status byte will be set. Use the *STB? query to obtain the status byte, then test bit 2 to see if it is set. If the EAV bit is set, an error has occurred, and you can use the appropriate error query to read the error and at the same time clear the EAV bit in the status byte.

Generating an SRQ on error

To program the instrument to generate an IEEE-488 bus SRQ (Service Request) when an error occurs, send the following command: *SRE 4. This command will enable SRQ when the EAV bit is set. You can then read the status byte and error queue as outlined above to check for errors and to determine the exact nature of the error.

Detecting calibration step completion

When sending remote calibration commands, you must wait until the instrument completes the current operation before sending another command. You can use either `*OPC?` or `*OPC` to help determine when each calibration step is completed.

Using the `*OPC?` query

With the `*OPC?` (operation complete) query, the instrument will place an ASCII 1 in the output queue when it has completed each step. To determine when the OPC response is ready, do the following:

1. Repeatedly test the MAV (Message Available) bit (bit 4) in the status byte and wait until it is set. (You can request the status byte by using the `*STB?` query.)
2. When MAV is set, a message is available in the output queue, and you can read the output queue and test for an ASCII 1.
3. After reading the output queue, repeatedly test MAV again until it clears. At this point, the calibration step is completed.

Using the `*OPC` command

The `*OPC` (operation complete) command can also be used to detect the completion of each calibration step. In order to use `*OPC` to detect the end of each calibration step, do the following:

1. Enable operation complete by sending `*ESE 1`. This command sets the OPC (operation complete bit) in the standard event enable register, allowing operation complete status from the standard event status register to set the ESB (event summary bit) in the status byte when operation complete is detected.
2. Send the `*OPC` command immediately following each calibration command. For example:

```
:CAL:PROT:SENS 2;*OPC
```

Note that you must include the semicolon (;) to separate the two commands, and that the `*OPC` command must appear on the same line as the command.
3. After sending a calibration command, repeatedly test the ESB (Event Summary) bit (bit 5) in the status byte until it is set. (Use `*STB?` to request the status byte.)
4. Once operation complete has been detected, clear OPC status using one of two methods: (1) use the `*ESR?` query, then read the response to clear the standard event status register, or (2) send the `*CLS` command to clear the status registers. Note that sending `*CLS` will also clear the error queue and operation complete status.

Generating an SRQ on calibration complete

An IEEE-488 bus SRQ (service request) can be used to detect operation complete instead of repeatedly polling the Model 2440. To use this method, send both *ESE 1 and *SRE 32 to the instrument, then include the *OPC command at the end of each calibration command line, as covered above. Clear the SRQ by querying the ESR (using the *ESR? query) to clear OPC status, then request the status byte with the *STB? query.

Refer to your controller's documentation for information on detecting and servicing SRQs.

C Calibration Programs

Introduction

This appendix includes a calibration program written in BASIC to help you in calibrate the Model 2440, as well as an example program that demonstrates how to request calibration constants. Refer to [Section 2](#) for more details on calibration procedures, equipment, and connections. [Appendix B](#) covers calibration commands in detail.

Computer hardware requirements

The following computer hardware is required to run the calibration programs:

- IBM PC compatible computer.
- Keithley KPC-488.2, KPS-488.2, or KPC-488.2AT, or CEC PC-488 IEEE-488 interface for the computer.
- Two shielded IEEE-488 connecting cables (Keithley Model 7007).

Software requirements

In order to use the calibration programs, you will need the following computer software:

- Microsoft QBasic (supplied with MS-DOS 5.0 or later).
- MS-DOS version 5.0 or later.
- HP-style Universal Language Driver, CECHP.EXE (supplied with Keithley and CEC interface cards listed above).

Calibration equipment

The following calibration equipment is required:

- Hewlett-Packard HP3458A Digital Multimeter
- 1Ω , $\pm 0.1\%$, 100W resistor

See [Section 2](#) for detailed equipment specifications.

General program instructions

1. With the power off, connect the Model 2440 and the digital multimeter to the IEEE-488 interface of the computer. Be sure to use shielded IEEE-488 cables for bus connections.
2. Turn on the computer, the Model 2440, and the digital multimeter. Allow the Model 2440 and the multimeter to warm up for at least one hour before performing calibration.
3. Make sure the Model 2440 is set for a primary address of 24. (Use the front panel MENU/GPIB selection to check or change the address.)
4. Make sure the digital multimeter primary address is set to its factory default setting (22).
5. Make sure that the computer bus driver software (CECHP.EXE) is properly initialized.
6. Enter the QBasic editor, and type in the program below.

NOTE *Be sure to change the OneOhm parameter to the characterized value of 1Ω resistor. (See [Section 2](#) for details.)*

7. Check thoroughly for errors, then save it using a convenient filename.
8. Run the program, and follow the prompts on the screen to perform calibration. For test connections, refer to the following figures in [Section 2](#):
 - DMM volts connections: [Figure 2-1](#).
 - 10μA to 1A range current connections: [Figure 2-2](#).
 - 1Ω resistor and DMM connections for 5A range: [Figure 2-3](#).

Program C-1 Model 2440 calibration program

' Model 2440 calibration program for use with the HP3458A Digital Multimeter.

```
' Rev. 1.0, 2/1/2001
' 2440 primary address = 24. HP3458A primary address = 22.
OPEN "IEEE" FOR OUTPUT AS #1      ' Open IEEE-488 output path.
OPEN "IEEE" FOR INPUT AS #2      ' Open IEEE-488 input path.
PRINT #1, "INTERM CRLF"         ' Set input terminator.
PRINT #1, "OUTTERM LF"          ' Set output terminator.
PRINT #1, "REMOTE 22 24"        ' Put 2440, 3458A in remote.
PRINT #1, "CLEAR"               ' Send DCL.
PRINT #1, "OUTPUT 24;*CLS"       ' Initialize 2440.
PRINT #1, "OUTPUT 24;*ESE 1;*SRE 32" ' Enable OPC and SRQ.
PRINT #1, "OUTPUT 22;PRESET NORM" ' Initialize 3458A.
PRINT #1, "OUTPUT 22;NPLC 10;NDIG 7;TRIG LINE;FUNC DCV,AUTO"
'
OneOhm = 1                        ' Use characterized 1 ohm value.
CLS
PRINT "Model 2440 Calibration Program"
PRINT "Connect DMM volts input to Model 2440 INPUT/OUTPUT jacks."
GOSUB KeyCheck
FOR J = 1 TO 2                    ' Select volts/current cal.
IF J = 1 THEN
    RESTORE VoltsInit
    Max = 8
    Range = .2
    Limit = 40
ELSE
    RESTORE CurrentInit
    Max = 4
    Range = .00001
    Limit = 5
    PRINT #1, "OUTPUT 24;:OUTP:STAT OFF"
    PRINT #1, "OUTPUT 22;FUNC DCI,AUTO"
    PRINT "Connect DMM current input to 2440 INPUT/OUTPUT jacks."
    GOSUB KeyCheck
END IF
Source = Range
FOR I = 1 TO Max: READ Cmd$: PRINT #1, "OUTPUT 24;"; Cmd$: NEXT I
WHILE Range <= Limit              ' Cal all ranges.
IF J = 1 THEN RESTORE VoltsCal ELSE RESTORE CurrentCal
FOR I = 1 TO 12
    READ Cmd$
    SELECT CASE I
        CASE 1
            PRINT #1, "OUTPUT 24;"; Cmd$; Range
        CASE 2
            PRINT #1, "OUTPUT 24;"; Cmd$; -Source
            GOSUB ReadDMM
        CASE 3, 4, 6, 7, 9, 10, 12
            PRINT #1, "OUTPUT 24;"; Cmd$; Reading$; ";*OPC"
```

```

        GOSUB ErrCheck
        GOSUB CalEnd
    CASE 5, 11
        PRINT #1, "OUTPUT 24;"; Cmd$
        GOSUB ReadDMM
    CASE 8
        PRINT #1, "OUTPUT 24;"; Cmd$; Source
        GOSUB ReadDMM
END SELECT
NEXT I
Range = Range * 10
IF J = 1 AND Range = 20 THEN Range = 10
IF J = 1 AND Range = 100 THEN Range = 40
IF J = 2 AND Range > 9 AND Range < 11 THEN
    Range = 5
    PRINT #1, "OUTPUT 24;:OUTP:STAT OFF"
    PRINT #1, "OUTPUT 22;FUNC DCV,AUTO"
    PRINT "Connect 1 Ohm resistor and DMM volts input to 2440."
    GOSUB KeyCheck
    PRINT #1, "OUTPUT 24;:OUTP:STAT ON"
END IF
Source = Range
WEND
NEXT J
PRINT #1, "OUTPUT 24;:OUTP:STAT OFF"
LINE INPUT "Enter calibration date (yyyy,mm,dd): "; D$
PRINT #1, "OUTPUT 24;:CAL:PROT:DATE "; D$
LINE INPUT "Enter calibration due date (yyyy,mm,dd): "; D$
PRINT #1, "OUTPUT 24;:CAL:PROT:NDUE "; D$
PRINT #1, "OUTPUT 24;:CAL:PROT:SAVE"      ' Save calibration constants.
GOSUB ErrCheck
PRINT #1, "OUTPUT 24;:CAL:PROT:LOCK"      ' Lock out calibration.
PRINT "Calibration completed."
PRINT #1, "OUTPUT 24;*RST"
PRINT #1, "LOCAL 22 24"
CLOSE
END
'
KeyCheck:                                ' Check for key press routine.
WHILE INKEY$ <> "": WEND                  ' Flush keyboard buffer.
PRINT : PRINT "Press any key to continue (ESC to abort program).".
DO: I$ = INKEY$: LOOP WHILE I$ = ""
IF I$ = CHR$(27) THEN GOTO EndProg        ' Abort if ESC is pressed.
RETURN
'
CalEnd:                                    ' Check for cal step completion.
DO: PRINT #1, "SRQ?"                      ' Request SRQ status.
    INPUT #2, S                            ' Input SRQ status byte.
LOOP UNTIL S                              ' Wait for operation complete.
PRINT #1, "OUTPUT 24;*ESR?"              ' Clear OPC.
PRINT #1, "ENTER 24"

```

```

INPUT #2, S
PRINT #1, "SPOLL 24"           ' Clear SRQ.
INPUT #2, S
RETURN
'
ErrCheck:                      ' Error check routine.
PRINT #1, "OUTPUT 24;:SYST:ERR?" ' Query error queue.
PRINT #1, "ENTER 24"
INPUT #2, E, Err$
IF E <> 0 THEN PRINT Err$: GOTO EndProg' Display error.
RETURN
'
ReadDMM:                       ' Get reading from DMM.
SLEEP 5
PRINT #1, "ENTER 22"
INPUT #2, Reading$
IF J = 2 AND Range = 3 THEN Reading$ = STR$(VAL(Reading$) / OneOhm)
RETURN
'
EndProg:                       ' Close files, end program.
BEEP: PRINT "Calibration aborted."
PRINT #1, "OUTPUT 24;:CAL:PROT:LOCK"
PRINT #1, "OUTPUT 24;*RST"
PRINT #1, "LOCAL 22 24"
CLOSE
END
'
VoltsInit:                     ' Calibration command lists.
DATA "*RST",":SOUR:FUNC VOLT",":SENS:CURR:PROT 0.1"
DATA ":SENS:CURR:RANG 0.1",":SOUR:VOLT:PROT:LEV MAX",":SYST:RSEN OFF"
DATA ":CAL:PROT:CODE 'KI002440'",":OUTP:STAT ON"
VoltsCal:
DATA ":SOUR:VOLT:RANG ",":SOUR:VOLT "
DATA ":CAL:PROT:SOUR ",":CAL:PROT:SENS ",":SOUR:VOLT 0.0"
DATA ":CAL:PROT:SOUR ",":CAL:PROT:SENS ",":SOUR:VOLT ",":CAL:PROT:SOUR "
DATA ":CAL:PROT:SENS ",":SOUR:VOLT 0.0",":CAL:PROT:SOUR "
CurrentInit:
DATA ":SOUR:FUNC CURR",":SENS:VOLT:PROT 10",":SENS:VOLT:RANG 10"
DATA ":OUTP:STAT ON"
CurrentCal:
DATA ":SOUR:CURR:RANG ",":SOUR:CURR ",":CAL:PROT:SOUR "
DATA ":CAL:PROT:SENS ",":SOUR:CURR 0.0",":CAL:PROT:SOUR ",":CAL:PROT:SENS "
DATA ":SOUR:CURR ",":CAL:PROT:SOUR ",":CAL:PROT:SENS "
DATA ":SOUR:CURR 0.0",":CAL:PROT:SOUR "

```

Requesting calibration constants

Program C-2 listed below demonstrates how to request the calibration constants from the Model 2440. The program requests and displays the calibration constants for all ranges of both the volts and current source and measurement functions.

Program C-2 Requesting calibration constants

```
' Example program to request calibration constants.
' Model 2440 primary address = 24
OPEN "IEEE" FOR OUTPUT AS #1          ' Open IEEE-488 output path.
OPEN "IEEE" FOR INPUT AS #2          ' Open IEEE-488 input path.
PRINT #1, "INTERM CRLF"              ' Set input terminator.
PRINT #1, "OUTTERM LF"               ' Set output terminator.
PRINT #1, "REMOTE 24"                ' Put 2440 in remote.
PRINT #1, "OUTPUT 24;*RST"           ' Restore defaults.
CLS
PRINT #1, "OUTPUT 24;:SENS:FUNC:CONC OFF"
PRINT #1, "OUTPUT 24;:SENS:FUNC 'VOLT:DC'"
PRINT #1, "OUTPUT 24;:SOUR:FUNC VOLT"
PRINT #1, "OUTPUT 24;:CAL:PROT:CODE 'KI002440'" ' Unlock calibration.
Range = .2                            ' Initial range = 200mV.
PRINT "Model 2440 Voltage Calibration Constants:": PRINT
DO                                     ' Loop for all volts ranges.
    PRINT #1, "OUTPUT 24;:SOUR:VOLT:RANGE "; Range
    PRINT #1, "OUTPUT 24;:CAL:PROT:SENS:DATA?"
    PRINT #1, "ENTER 24"
    LINE INPUT #2, Data$
    PRINT Data$
    PRINT #1, "OUTPUT 24;:CAL:PROT:SOUR:DATA?"
    PRINT #1, "ENTER 24"
    LINE INPUT #2, Data$
    PRINT Data$
    Range = Range * 10
    IF Range = 20 THEN Range = 10
    IF Range = 100 THEN Range = 40
LOOP WHILE Range <= 60
PRINT #1, "OUTPUT 24;:CAL:PROT:LOCK"
PRINT #1, "OUTPUT 24;:SENS:FUNC 'CURR:DC'"
PRINT #1, "OUTPUT 24;:SOUR:FUNC CURR"
PRINT #1, "OUTPUT 24;:CAL:PROT:CODE 'KI002440'"
Range = .00001                          ' Initial range = 10uA.
PRINT : PRINT "Model 2440 Current Calibration Constants:": PRINT
DO                                     ' Loop for all current ranges.
    PRINT #1, "OUTPUT 24;:SOUR:CURR:RANGE "; Range
    PRINT #1, "OUTPUT 24;:CAL:PROT:SENS:DATA?"
    PRINT #1, "ENTER 24"
    LINE INPUT #2, Data$
    PRINT Data$
    PRINT #1, "OUTPUT 24;:CAL:PROT:SOUR:DATA?"
```

```
PRINT #1, "ENTER 24"
LINE INPUT #2, Data$
PRINT Data$
Range = Range * 10
IF Range > 9 AND Range < 11 THEN Range = 5
LOOP WHILE Range <= 3
PRINT #1, "OUTPUT 24;:CAL:PROT:LOCK"      ' Lock out calibration.
PRINT #1, "OUTPUT 24;*RST"
PRINT #1, "LOCAL 24"
CLOSE
END
```

Index

Numerics

- 10mA to 1A range accuracy 1-13, 1-16
- 1Ω resistor characterization 1-4, 2-4
- 5A range accuracy 1-14, 1-17

A

- A/D converter 4-9
- Accuracy
 - 10mA to 1A range 1-13, 1-16
 - 5A range 1-14, 1-17
 - Current measurement 1-16
 - Current measurement limits 1-17
 - Ohms measurement limits 1-19
 - Output current 1-13
 - Output current limits 1-15
 - Output voltage 1-10
 - Output voltage limits 1-11
 - Resistance measurement 1-18
 - Voltage measurement 1-12
 - Voltage measurement limits 1-12
- Active guard 4-9
- Analog board
 - Parts list 6-3
 - Removal 5-5
- Analog circuitry
 - Block diagram 4-6
 - Checks 4-14
- Analog circuits 4-4

B

- Battery replacement 4-14
 - Precautions 4-15
 - Procedure 4-15
- Block diagrams
 - Analog circuitry 4-6
 - Digital circuitry 4-10
 - Overall 4-5
 - Power supply 4-7

C

- Calibration 2-1
 - Considerations 2-3
 - Constants 2-25
 - Count 2-8
 - Current 2-13, 2-23
 - Current calibration initialization commands 2-24
 - Current range calibration commands 2-24
 - Cycle 2-3
 - Dates 2-8, 2-17, 2-25
 - Detecting errors B-9
 - Detecting step completion B-11
 - Equipment C-2
 - Errors 2-8, B-10
 - Front panel operation 2-9
 - Locking out 2-17, 2-25
 - Password 2-7, 2-8
 - Programs C-1
 - Recommended equipment 2-4
 - Recommended parameter ranges 2-19, B-7, B-8
 - Remote calibration command summary B-2
 - Remote commands 2-18
 - Remote procedure 2-20
 - Remote programming 2-18
 - Requesting constants C-7
 - Saving 2-17
 - Single-range 2-25
 - Unlocked states 2-6
 - Unlocking 2-5
 - Voltage 2-10, 2-21
 - Voltage calibration initialization commands 2-22
 - Voltage range calibration commands 2-22
- Case cover removal 5-4
- Commands
 - *OPC B-11
 - *OPC? query B-11
 - CODE B-3
 - COUNT? B-3

- Current calibration initialization [2-24](#)
- Current range calibration [2-24](#)
- DATA? [B-9](#)
- DATE [B-5](#)
- LOCK [B-4](#)
- NDUE [B-5](#)
- Reference [B-1](#)
- Remote calibration [2-18](#), [B-2](#)
- SAVE [B-4](#)
- SENSE [B-6](#)
- SOURCE [B-7](#)
- Voltage calibration initialization [2-22](#)
- Voltage range calibration [2-22](#)
- Compliance
 - Considerations [1-8](#)
 - Determining limit [1-9](#)
 - Limits [1-8](#)
 - Maximum values [1-9](#)
 - Taking the SourceMeter out of compliance [1-10](#)
 - Types [1-8](#)
- Connections
 - 10 μ A to 1A range current calibration test [2-13](#)
 - 10 μ A to 1A range current verification tests [1-13](#)
 - 5A range current calibration test [2-15](#)
 - 5A range current verification tests [1-14](#)
 - Resistance accuracy verification [1-18](#)
 - Voltage calibration test [2-10](#)
 - Voltage verification tests [1-10](#)
- Current calibration [2-13](#), [2-23](#)
- Current measurement
 - Accuracy [1-16](#)

D

- Digital board
 - Parts list [6-12](#)
 - Removal [5-6](#)
- Digital circuitry [4-10](#)
 - Block diagram [4-10](#)
 - Checks [4-13](#)
- Digital circuits [4-4](#)
- Disassembly [5-1](#)
 - Front panel [5-6](#)
- Display board
 - Checks [4-12](#)
 - Circuit theory [4-11](#)
 - Parts list [6-17](#)

E

- Environmental conditions [1-2](#), [2-2](#)
- Error reporting
 - Front panel [2-8](#)
 - Remote [2-9](#)
- Errors
 - Calibration [2-8](#), [B-9](#)
 - Generating an SRQ on error [B-10](#)
 - No comm link [4-16](#)
 - Reading the error queue [B-9](#)
 - Reporting see *Error reporting*
 - Summary [B-9](#)
- Examples
 - Limits calculation [1-5](#)

F

- Factory defaults
 - Restoring [1-6](#)
- Factory service [6-2](#)
- Front panel
 - Disassembly [5-6](#)
 - Error reporting [2-8](#)
 - Tests [4-3](#)
- Front panel operation
 - Calibration [2-9](#)
 - Changing the password [2-7](#)
 - Unlocking calibration [2-5](#)
- Fuse replacement [3-2](#)

H

- Handling and cleaning [5-2](#)
- Handling PC boards [5-2](#)
- Hardware requirements [C-2](#)

I

- Instrument reassembly [5-7](#)

L

- Limits
 - Calculation [1-5](#)
 - Compliance [1-8](#), [1-9](#)
 - Current measurement accuracy [1-17](#)
 - Ohms measurement accuracy [1-19](#)
 - Output current accuracy [1-15](#)
 - Output voltage accuracy [1-11](#)
 - Resistance limits calculation [1-5](#)
 - Verification [1-5](#)
 - Voltage measurement accuracy [1-12](#)
- Line power [1-3](#), [2-2](#)
 - Fuse replacement [3-2](#)
- Lock out calibration [2-17](#), [2-25](#)

M

- Measurement range
 - Setting 1-8

N

- No comm link error 4-16

O

- Operation principles 4-4
- Ordering information 6-2
- Output current
 - Accuracy 1-13
- Output stage 4-8
 - Simplified schematic 4-8
- Output value
 - Setting 1-7
- Output voltage
 - Accuracy 1-10

P

- Parameters
 - Calibration 2-19, B-7, B-8
- Parts lists
 - Analog board 6-3
 - Digital board 6-12
 - Display board 6-17
 - Miscellaneous 6-18
- Password
 - Changing 2-7
 - Resetting 2-8
- Performance verification 1-1
- Power components
 - Removal 5-7
- Power module removal 5-7
- Power supplies 4-4
- Power supply 4-7
 - Block diagram 4-7
 - Checks 4-12
- Power-on self-test 4-2
- Program instructions C-3

R

- Range
 - Measurement 1-8
 - Source 1-7
- Recommended equipment
 - Calibration 2-4
 - Tests 1-3
 - Verification 1-3
- Relative humidity 2-2
- Remote operation
 - Calibration procedure 2-20
- Remote programming
 - Calibration 2-18
 - Changing the password 2-7
 - Unlocking calibration 2-6
- Repair considerations 4-2
- Replaceable Parts 6-11
- Replaceable parts 6-1
- Resistance limits calculation 1-5
- Resistance measurement
 - Accuracy 1-18
- Resistors
 - 1 Ω characterization 1-4, 2-4
- Routine maintenance 3-1

S

- Service Request *see* SRQ
- Software requirements C-2
- Solder repairs 5-2
- Source range
 - Setting 1-7
- Specifications A-1
- SRQ B-10, B-12
- Static sensitive devices 5-3
- Status byte EAV (Error Available) bit B-10

T

Temperature 2-2

Ambient 1-2, 2-2

Tests

CHAR SET 4-4

DISPLAY PATTERNS 4-3

Equipment 1-3

Front panel 4-3

KEYS 4-3

Power-on self-test 4-2

Verification procedures 1-6

Verification requirements 1-2

Verification test considerations 1-7

Troubleshooting 4-1

U

Unlocking calibration 2-5

V

Verification

10mA to 1A range current test
connections 1-13

5A range current test connections 1-14

Equipment 1-3

Limits 1-5

Performance 1-1

Performing test procedures 1-6

Resistance accuracy connections 1-18

Test considerations 1-7

Test requirements 1-2

Voltage test connections 1-10

Voltage

Calibration 2-10, 2-21

Measurement accuracy 1-12

W

Warm-up period 1-3, 2-2

Service Form

Model No. _____ **Serial No.** _____ **Date** _____

Name and Telephone No. _____

Company _____

List all control settings, describe problem and check boxes that apply to problem. _____

Intermittent Analog output follows display Particular range or function bad; specify _____

IEEE failure Obvious problem on power-up Batteries and fuses are OK

Front panel operational All ranges or functions are bad Checked all cables

Display or output (check one)

Drifts Unable to zero Unstable

Overload Will not read applied input

Calibration only Certificate of calibration required Data required

(attach any additional sheets as necessary)

Show a block diagram of your measurement including all instruments connected (whether power is turned on or not). Also, describe signal source.

Where is the measurement being performed? (factory, controlled laboratory, out-of-doors, etc.) _____

What power line voltage is used? _____ Ambient temperature? _____ °F

Relative humidity? _____ Other? _____

Any additional information. (If special modifications have been made by the user, please describe.)

Be sure to include your name and phone number on this service form.

Specifications are subject to change without notice.

All Keithley trademarks and trade names are the property of Keithley Instruments, Inc. All other trademarks and trade names are the property of their respective companies.



Keithley Instruments, Inc.

28775 Aurora Road • Cleveland, Ohio 44139 • 440-248-0400 • Fax: 440-248-6168
1-888-KEITHLEY (534-8453) www.keithley.com

BELGIUM: Keithley Instruments B.V.
CHINA: Keithley Instruments China
FRANCE: Keithley Instruments Sarl
GERMANY: Keithley Instruments GmbH
GREAT BRITAIN: Keithley Instruments Ltd.
INDIA: Keithley Instruments GmbH
ITALY: Keithley Instruments s.r.l.
KOREA: Keithley Instruments Korea
NETHERLANDS: Keithley Instruments B.V.
SWITZERLAND: Keithley Instruments SA
TAIWAN: Keithley Instruments Taiwan

Bergensesteenweg 709 • B-1600 Sint-Pieters-Leeuw • 02/363 00 40 • Fax: 02/363 00 64
Yuan Chen Xin Building, Room 705 • 12 Yumin Road, Dewai, Madian • Beijing 100029 • 8610-6202-2886 • Fax: 8610-6202-2892
3, allée des Garays • 91127 Palaiseau Cédex • 01 64 53 20 20 • Fax: 01 60 11 77 26
Landsberger Strasse 65 • D-82110 Germering • 089/84 93 07-40 • Fax: 089/84 93 07-34
The Minster • 58 Portman Road • Reading, Berkshire RG30 1EA • 0118-9 57 56 66 • Fax: 0118-9 59 64 69
Flat 2B, WILLOCRISSA • 14, Rest House Crescent • Bangalore 560 001 • 91-80-509-1320/21 • Fax: 91-80-509-1322
Viale San Gimignano, 38 • 20146 Milano • 02-48 39 16 01 • Fax: 02-48 30 22 74
2FL., URI Building • 2-14 Yangjae-Dong • Seocho-Gu, Seoul 137-130 • 82-2-574-7778 • Fax: 82-2-574-7838
Postbus 559 • NL-4200 AN Gorinchem • 0183-635333 • Fax: 0183-630821
Kriesbachstrasse 4 • 8600 Dübendorf • 01-821 94 44 • Fax: 01-820 30 81
1FL., 85 Po Ai Street • Hsinchu, Taiwan, R.O.C. • 886-3-572-9077 • Fax: 886-3-572-9031